



# PRODUCT BROCHURE **OVERVIEW**

GRP AUSTRALIA | 2024

GRP-BR-10-REV0



PRODUCT GUIDE 2024

PAGE  
NUMBER

# CONTENTS

- 03** OVERVIEW  
About GRP Australia, what is FRP & Advantages
- 04** MOULDED GRATING  
Standard surface finishes & colours. Product range, applications & gallery
- 08** STRUCTURAL SECTIONS  
Standard resins & colours. Product range, applications & gallery
- 12** MODULAR HANDRAIL  
Standard details & colours. Product range, applications & gallery
- 16** PULTRUDED DECKING  
Product Range, Applications & Gallery
- 18** COMPOSITE FASTENERS  
Product Range, Applications & Gallery
- 20** FIBRE FRAME  
Product Range, Applications & Gallery



## ABOUT GRP AUSTRALIA

GRP Australia is a Brisbane based, family owned and operated company. As an independent supplier we source and import FRP pultruded structural sections, FRP grating and other related products from trusted quality manufacturers. This enables us to provide our customers with quality products at competitive prices.

## WHAT IS FRP?

FRP (fibreglass reinforced polymer), also known as fibreglass is a composite material made primarily of glass fibres and a thermosetting resin. The two main products supplied by GRP Australia are structural sections and moulded grating. Our FRP Structural Sections are a manufactured fiberglass product made in a continuous pultruded process while FRP Moulded Grating is a fiberglass decking product made in a batch process.

The exceptional high strength to weight ratio and versatility of FRP allows it to be used in various applications, while its customizability makes it ideal for meeting specific industry needs.

## ADVANTAGES



Cost  
Competitive



Non-corrosive &  
rot resistant



As strong as  
steel



Termite and  
vermin proof



High fire  
resistance



UV  
Stabilised



Lightweight & easy  
to manoeuvre



# FRP MOULDED GRATING

4

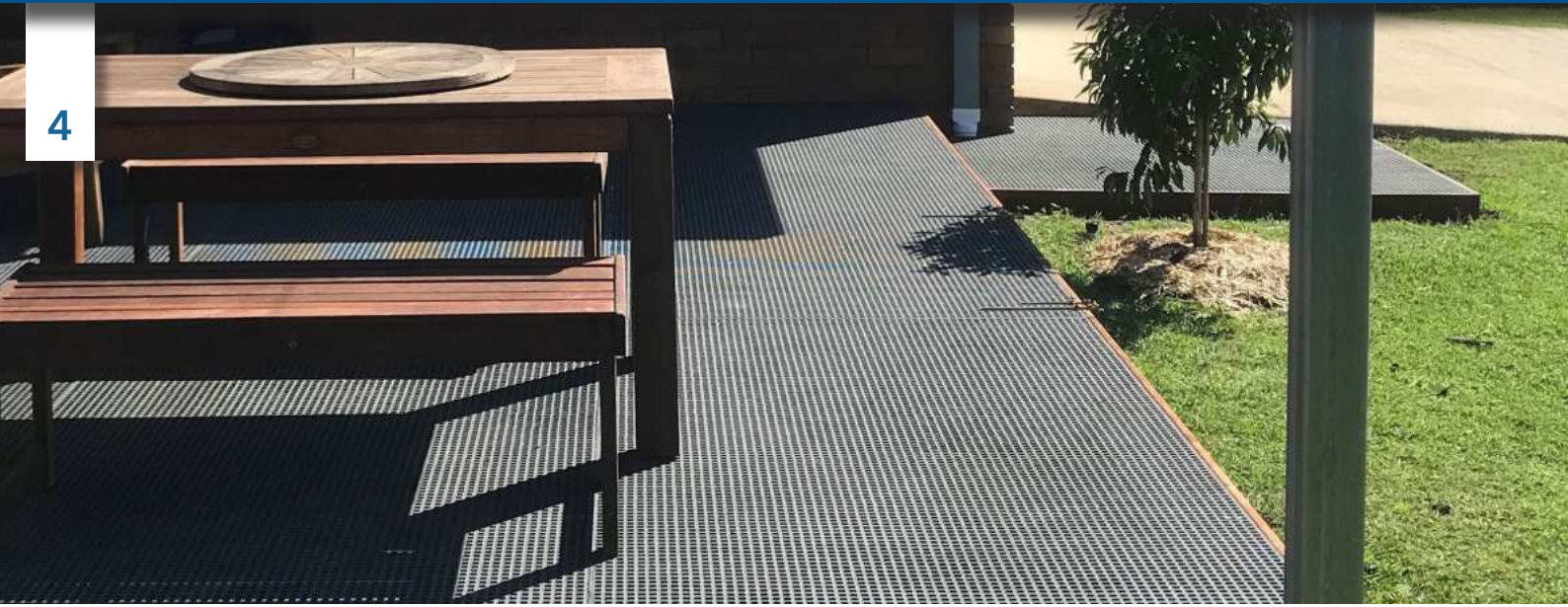

GRP Australia supplies high-quality FRP Moulded Grating, designed for strength, durability, and versatility across a wide range of industrial, commercial & residential applications. Available in various surface finishes and a broad spectrum of colors, our moulded grating is designed to address diverse safety and environmental conditions. Whether you require slip resistance, chemical resistance, or a specific aesthetic, GRP Australia's FRP Moulded Grating provides the ideal solution.

## SURFACE FINISHES

GRP Australia supply a wide range of surface finishes for FRP moulded grating, each providing varying levels of slip resistance and durability to suit different environmental conditions.



Glass **Beaded**



Standard **Grit**



Fine **Grit**



Flat **Surface**



Concave **Finish**



Solid **Grit Top**

## STANDARD COLOUR RANGE

GRP Australia offer six standard colours in FRP Moulded Grating & Stair Treads



GRASS GREEN  
**RAL6010**



SLATE GREY  
**RAL7015**



SIGNAL YELLOW  
**RAL1003**



LIGHT GREY  
**RAL9006**



BLACK GREY  
**RAL7021**



SIGNAL BLACK  
**RAL9004**

## PRODUCT RANGE | MOULDED GRATING

GRP Australia offers a comprehensive range of FRP Moulded Grating, all designed for superior strength, safety, and durability. Whether you need general-purpose grating or custom solutions, we have the perfect fit for your project.

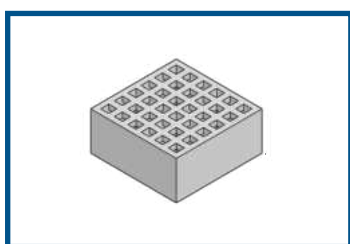

**13x13/40x40 HEEL GUARD**

**Hole Aperture:** 8mm  
**Thickness:** 25, 30 & 38mm

**Sheet Size:**  
1007 x 3007mm  
1247 x 4047mm

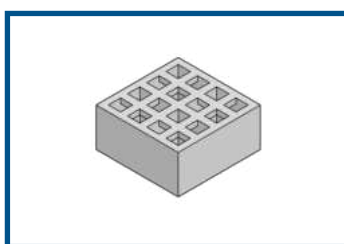

**19x19/38x38 MINI MESH**

**Hole Aperture:** 13mm  
**Thickness:** 25, 30 & 38mm

**Sheet Size:**  
1226 x 2445mm  
1226 x 3665mm

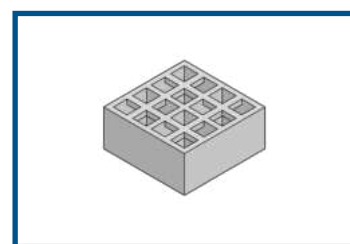

**20x20/40x40 MICRO MESH**

**Hole Aperture:** 14mm  
**Thickness:** 25, 30 & 38mm

**Sheet Size:**  
1007 x 3007mm  
1247 x 4047mm

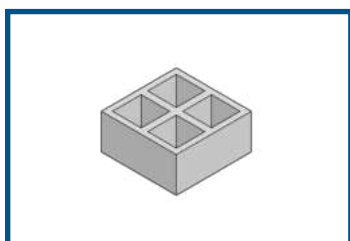

**38x38 STANDARD**

**Hole Aperture:** 33mm  
**Thickness:** 15, 25, 30 & 38mm

**Sheet Size:**  
615 x 3665mm  
1226 x 3665mm

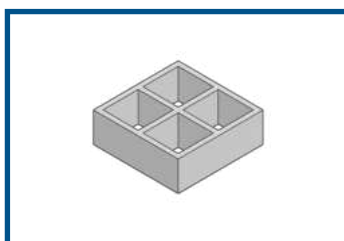

**50x50 STANDARD**

**Hole Aperture:** 44mm  
**Thickness:** 25, 40, 50mm

**Sheet Size:**  
1230 x 4020mm

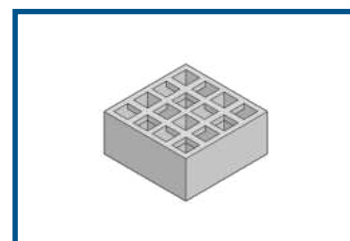

**26x26/52x52 AGRI MESH**

**Hole Aperture:** 19mm  
**Thickness:** 30 & 38mm

**Sheet Size:**  
998 x 3075mm

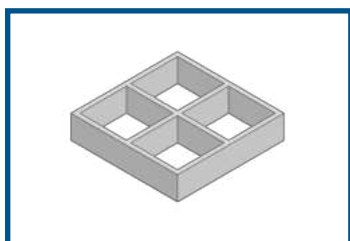

**83x83 STANDARD**

**Hole Aperture:** 76mm  
**Thickness:** 38 & 40mm

**Sheet Size:**  
1007 x 3007mm  
1247 x 4047mm

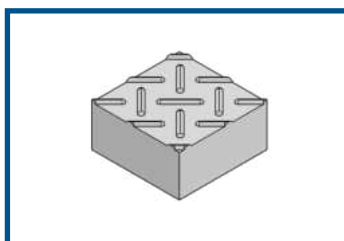

**DIAMOND TOP**

**Diamond Plated Surface**  
**Plate Thickness:** 3 or 5mm  
**Grating Thickness:** 25, 30 & 38mm

**Sheet Size:**  
1226 x 3665mm

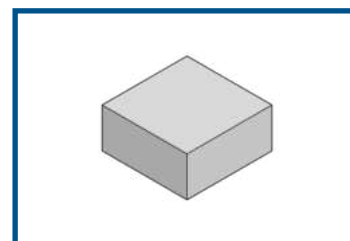

**SOLID TOP**

**Solid Grit Surface**  
**Plate Thickness:** 3 or 5mm  
**Grating Thickness:** 25, 30 & 38mm

**Sheet Size:**  
1226 x 3665mm

# FRP MOULDED GRATING

## 6 PRODUCT RANGE | STAIR TREADS

FRP Stair Treads are designed for maximum safety and durability, offering slip-resistant surfaces and exceptional resistance to corrosion, chemicals, and extreme weather conditions. Ideal for both indoor and outdoor environments, they provide long-lasting performance in industrial, commercial, and public settings.

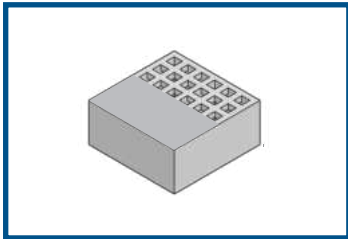

### 13x13/40x40 TREADS

**Hole Aperture:** 8mm  
**Moulded Nosing:** 44mm  
**Thickness:** 38mm

**Sheet Size:**  
287 x 3687mm

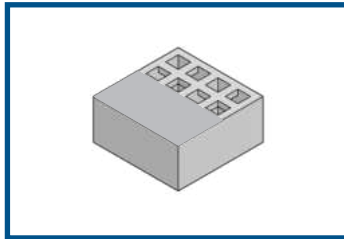

### 19x19/38x38 TREADS

**Hole Aperture:** 13mm  
**Moulded Nosing:** 44mm  
**Thickness:** 38mm

**Sheet Size:**  
275 x 1188mm  
275 x 3665mm

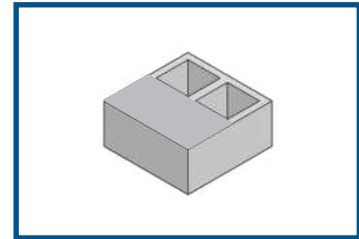

### 38x38 TREADS

**Hole Aperture:** 33mm  
**Moulded Nosing:** 44mm  
**Thickness:** 38mm

**Sheet Size:**  
275 x 3665mm



WANT TO FIND OUT MORE?

**SCAN QR CODE**  
TO VIEW FULL FRP MOULDED GRATING  
BROCHURE

CLICK TO VIEW



## APPLICATIONS

FRP Moulded Grating excels in challenging environments, offering outstanding performance in conditions where traditional materials may fail. It resists corrosion from chemicals, saltwater, and moisture. Additionally, its non-slip surface and resistance to extreme temperatures and UV exposure ensure safety and durability in harsh environments. These include:

- Industrial flooring and walkways
- Stair treads and landings
- Platform surfaces and decking
- Catwalks and access platforms
- Chemical processing plants
- Offshore and marine environments
- Wastewater treatment facilities
- Oil and gas facilities
- Cooling towers and power plants
- Pedestrian bridges and walkways
- Food and beverage processing areas
- Pulp and paper mills
- Conveyor system platforms
- Electrical substations

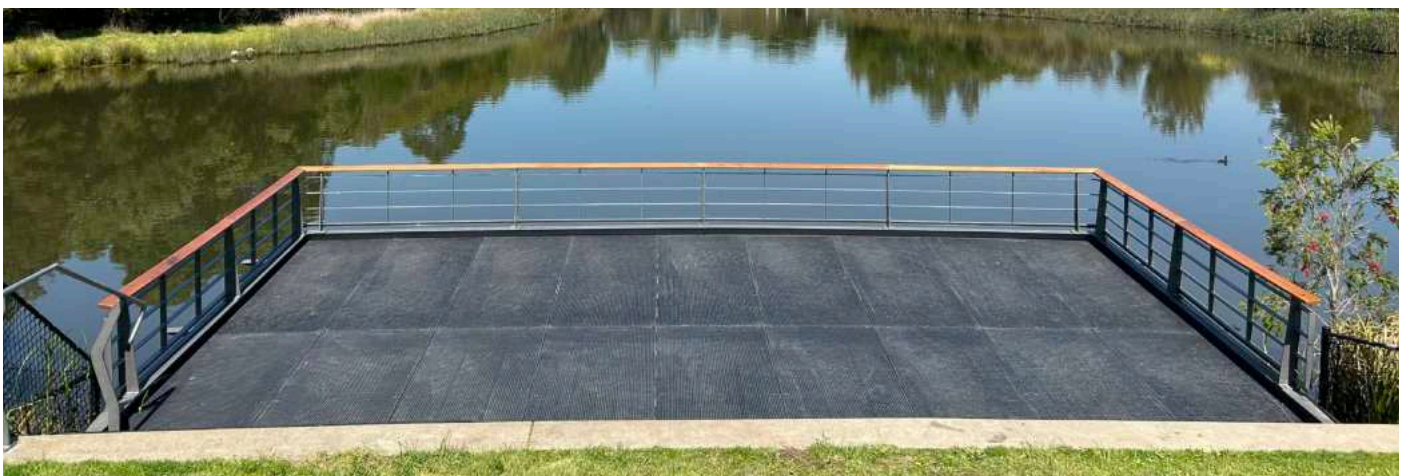

# FRP STRUCTURAL SECTIONS

8



FRP Structural Sections are high-performance, load-bearing profiles made from Fiberglass Reinforced Polymer designed to replace traditional materials like steel, aluminum, or wood in structural applications. These profiles are known for their exceptional strength, lightweight nature, and resistance to corrosion, chemicals, and environmental factors, making them ideal for use in demanding industrial, marine, and corrosive environments.

## STANDARD RESINS



### ISOPHTHALIC RESIN

Isophthalic resin is a high-performance polyester resin known for its excellent chemical resistance, durability, and strength. Commonly used in the production of FRP (Fiberglass Reinforced Plastic) products, it is ideal for applications that require resistance to corrosive environments, including chemical processing, marine, and industrial settings.



### VINYL ESTER RESIN

Vinyl ester resin is a versatile, high-performance resin offering superior chemical resistance, durability, and mechanical strength. It combines the benefits of epoxy and polyester resins, making it ideal for demanding applications in corrosive environments, such as chemical processing, marine, and industrial settings, where enhanced toughness and long-term performance are essential.

## STANDARD COLOUR RANGE

GRP Australia offer three standard colours in FRP Structural sections



TELEGREY 2  
RAL7046



SIGNAL YELLOW  
RAL1003



WINDOW GREY  
RAL7040



## PRODUCT RANGE | STRUCTURAL SECTIONS

FRP Structural Sections come in a wide variety of profiles, available in multiple sizes to suit diverse project needs. These lightweight, durable sections are designed for easy installation in construction and industrial applications.



### H BEAM

Profile Range: (mm)  
76 x 6.4 - 305 x 12.7  
(min) (max)



### I BEAM

Profile Range: (mm)  
15 x 32 x 6.4 - 152 x 305 x 12.7  
(min) (max)



### C CHANNEL

Profile Range: (mm)  
25 x 14 x 3 - 300 x 55 x 5  
(min) (max)



### Y BEAM

Profile Range: (mm)  
25 x 38 x 6.4 - 58 x 38 x 6.4  
(min) (max)



### SQUARE HOLLOW SECTION

Profile Range:  
25 x 3.2 - 152 x 12.7  
(min) (max)

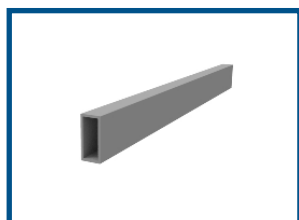

### RECTANGULAR HOLLOW SECTION

Profile Range:  
44 x 25 x 3.2 - 200 x 30 x 5  
(min) (max)



### CORRUGATED ROUND TUBE

Profile Range:  
19 x 32 x 6.4 - 71 x 90 x 9.5  
(min) (max)



### ROUND TUBE

Profile Range:  
25 x 3.2 - 150 x 9.5  
(min) (max)

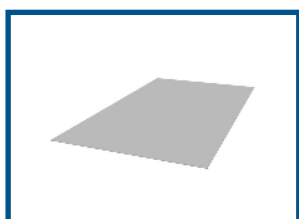

### FLAT PLATE

Profile Range: (mm)  
3.2 x 1000 - 25.4 x 1220  
(min) (max)

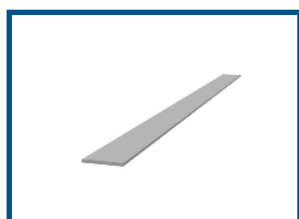

### FLAT STRIP

Profile Range: (mm)  
19 x 6.4 - 250 x 12  
(min) (max)

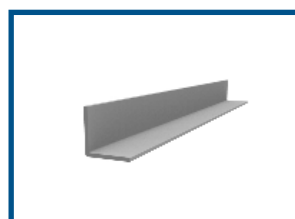

### EQUAL ANGLE

Profile Range: (mm)  
25 x 3.2 - 152 x 12.7  
(min) (max)

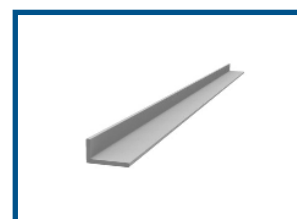

### UN-EQUAL ANGLE

Profile Range: (mm)  
40 x 22 x 4 - 254 x 40 x 6.4  
(min) (max)



### TOP HAT

Profile Range: (mm)  
90 x 30 x 30 x 4

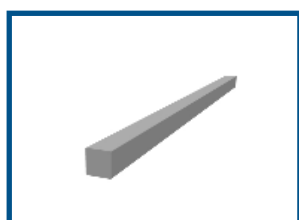

### SOLID SQUARE ROD

Profile Range: (mm)  
25 x 25 - 38 x 38  
(min) (max)



### SOLID ROUND ROD

Profile Range: (mm)  
6 - 38  
(min) (max)



### KICK PLATE

Profile Range: (mm)  
100 x 13 x 3.2 - 148 x 12 x 4  
(min) (max)

# FRP STRUCTURAL SECTIONS

## 10 CUSTOM PROFILES

GRP Australia have the capabilities of providing custom FRP profiles, tailored to your exact specifications. By providing detailed profile dimensions, we can offer precise pricing and deliver high-quality, durable profiles that meet your project's unique requirements. The lead time on this process is 3-4 weeks to produce the profile's pultrusion die & an additional 10 - 12 weeks to manufacture. You will need to keep in mind that a minimum order quantity of 100 lineal metres is required for custom / non-stocked profiles.

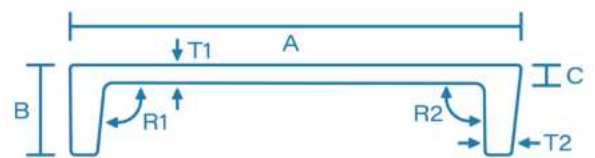

CUSTOM PROFILE  
(Example)

WANT TO FIND OUT MORE?

**SCAN QR CODE**  
TO VIEW FULL FRP STRUCTURAL  
SECTIONS BROCHURE

CLICK TO VIEW



## APPLICATIONS

FRP Structural Sections provide exceptional benefits in demanding environments where traditional materials are prone to deterioration. They are highly resistant to corrosion, chemicals, and moisture, making them ideal for use in corrosive environments. These sections also withstand extreme temperatures, UV exposure, and harsh weather conditions, ensuring long-term durability in outdoor and industrial settings. Their lightweight nature, combined with high strength, offers easy installation and low maintenance, even in the most challenging conditions. These include:

- Structural framing and supports
- Handrails and guardrails
- Platforms and walkways
- Pipe and cable trays
- Ladders and stairways
- Cooling tower structures
- Grating and flooring supports
- Bridge components and decking
- Offshore oil and gas platforms
- Chemical plant infrastructure
- Seawalls and coastal structures
- Electrical enclosures and panels
- Water treatment facilities
- Roof supports and purlins



# FRP MODULAR HANDRAIL

12



Our FRP modular handrail system uses round tube (RT50x5) made from premium vinyl ester resin which forms the top rail, knee rail and stanchions. The rails and stanchions are connected using BMC composite fittings which are fire retardant, non-corrosive and contain UV inhibitors. The fittings are clamped together with stainless steel fasteners provided by GRP Australia.

The modular handrail system has been designed and laboratory tested to be compliant with the requirements of AS 1657-2018. The minimum design requirements for FRP Modular Handrail have been set out in the diagram below.

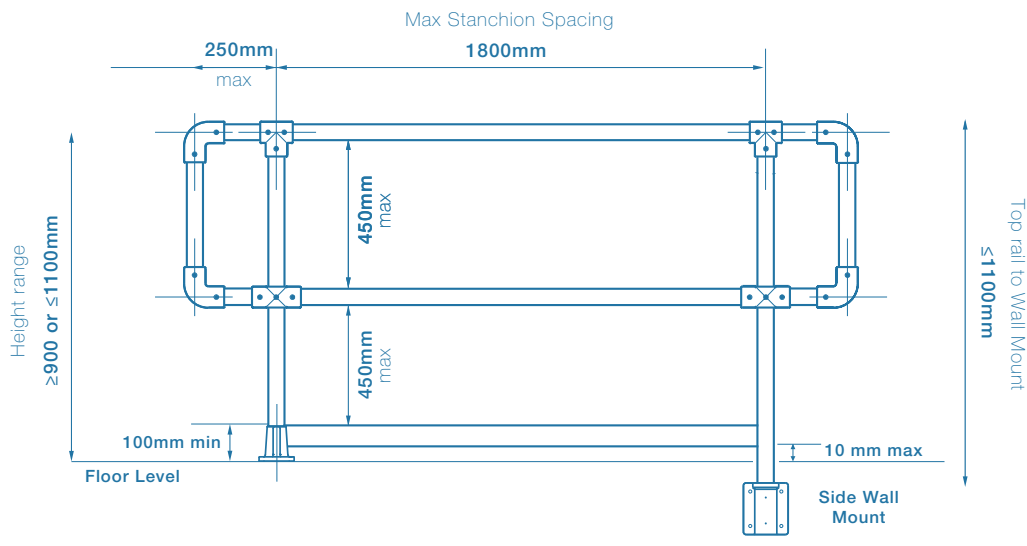

## STANDARD COLOUR RANGE

GRP Australia offer two standard colours in FRP Modular Handrail



SIGNAL YELLOW  
**RAL1003**



LIGHT GREY  
**RAL9006**

## PRODUCT RANGE | COMPONENTS

GRP Australia's FRP Modular Handrail product range offers a versatile and corrosion-resistant solution for safety and durability in various environments. Engineered for easy installation and long-term performance, our handrails provide a reliable alternative to traditional materials, ensuring optimal protection in demanding conditions.



**MH1-4 BASE-IB**  
Four hole  
base mount



**MH1-2 BASE**  
Two hole  
base mount



**MH1 WALL MOUNT**  
Stanchion  
wall mount



**MH1-SM**  
Stanchion  
sleeve mount



**MH1-END CAP**  
End tube  
cap



**MH2 90 ELBOW**  
90° degree  
elbow



**MH2 120 ELBOW**  
120° degree  
elbow



**MH2 135 ELBOW**  
135° degree  
elbow



**MH2-SC**  
Rail splice  
connector



**MH2-FLEX**  
Two way flexible  
angle connector



**MH3-30/45**  
30°/45° flexible  
connector



**MH3-W CROSS**  
Three way cross  
connector



**MH3 CORNER**  
Three way corner  
connector



**MH3-UNIVERSAL**  
Three way  
universal connector



**MH4-CONNECT**  
Four way cross  
connector



**MH4-CORNER**  
Four way  
corner connector



**MH4-FLEX**  
Four way flex  
connector



**MH4-UNIVERSAL**  
Four way  
universal connector



**KPM100x16x5**  
Kick plate  
M Style



**RT50x5**  
Round  
tube

# FRP MODULAR HANDRAIL

14



MHST-01  
Stanchion



MHST-02  
Stanchion



MHST-03  
Stanchion



MHST-04  
Stanchion



MHGT-01  
Gate

## HANDRAIL ASSEMBLY GUIDE

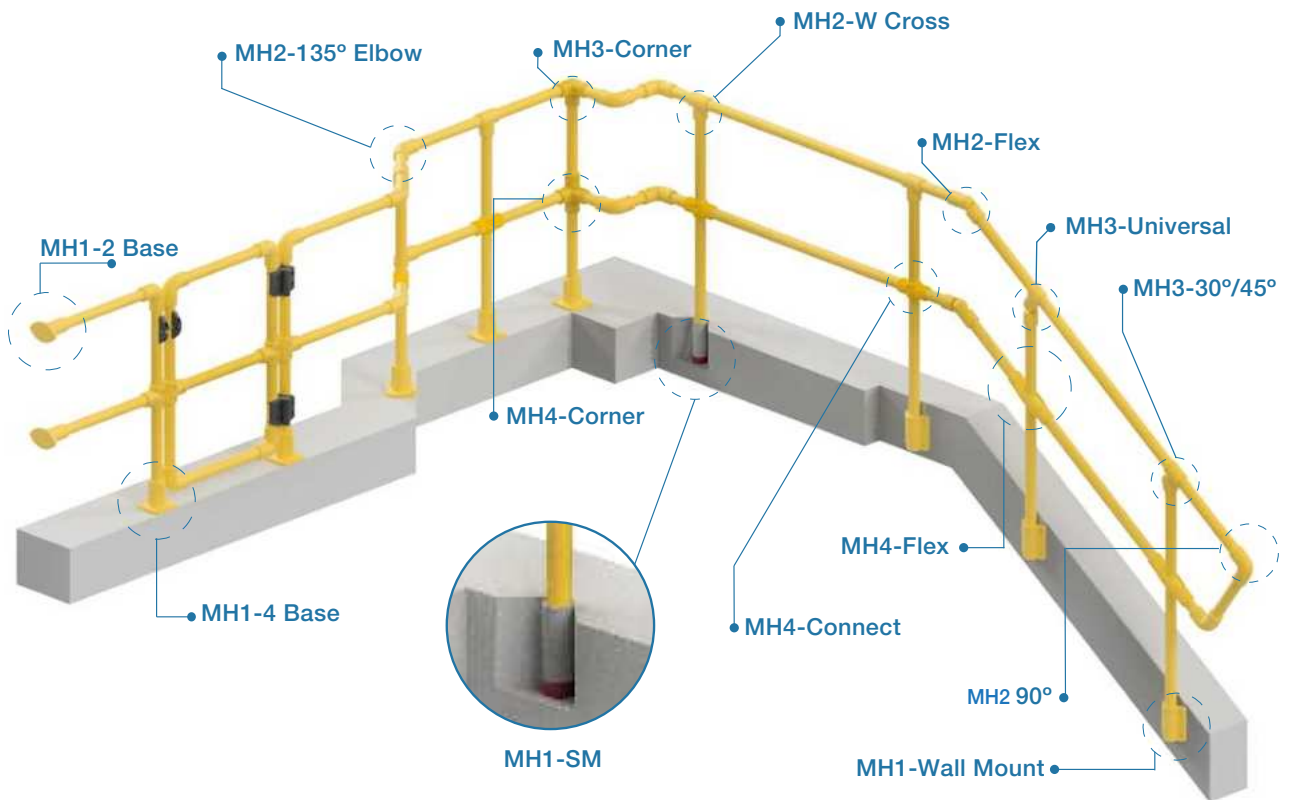

WANT TO FIND OUT MORE?

**SCAN QR CODE**  
TO VIEW FULL FRP HANDRAIL  
BROCHURE

CLICK TO VIEW



## APPLICATIONS

FRP Modular Handrails are specifically designed for environments exposed to harsh chemicals, moisture, and extreme weather, ensuring long-lasting performance where traditional materials often deteriorate. Ideal for industrial, marine, and coastal settings, these handrails offer superior corrosion resistance and safety in the most demanding conditions. These include:

- Industrial Walkways and Platforms
- Chemical Plants and Refineries
- Marine and Coastal Environments
- Water and Wastewater Treatment Plants
- Oil and Gas Facilities
- Mining and Mineral Processing Sites
- Public Infrastructure and Bridges
- Staircases and Ramps
- Power Generation Stations
- Food and Beverage Processing Plants
- Manufacturing Facilities
- Pulp and Paper Mills



# FRP PULTRUDED DECKING

16

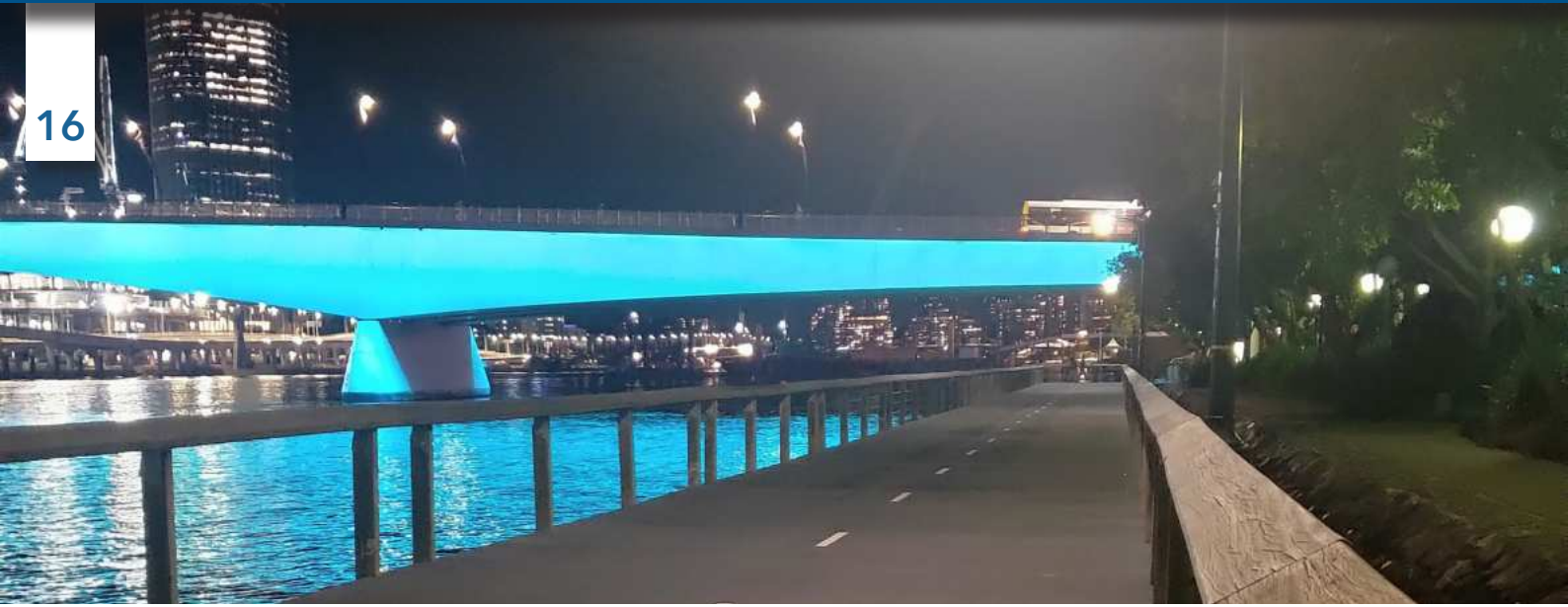

Pultruded FRP decking is perfect for industrial walkways and platforms, offering a safe & durable flooring solution. The non-slip surface enhances safety in both wet and dry conditions, making it a reliable choice for areas with high foot traffic or exposure to the elements. Its lightweight yet durable construction simplifies installation, while the material's resistance to corrosion, moisture, and UV rays ensures a long lifespan with minimal maintenance.

## APPLICATIONS

FRP pultruded decking is specifically engineered for environments exposed to harsh chemicals, moisture, and heavy traffic, making it perfect for industrial sites, marine platforms, and wastewater facilities. Its superior corrosion resistance ensures reliable performance and longevity in the most challenging conditions. These include:

- Bridges and Boardwalks
- Jetties & Pontoons
- Water and Wastewater Treatment Facilities
- Industrial Walkways and Catwalks
- Chemical Processing Plants
- Offshore Oil and Gas Platforms
- Cooling Towers
- Corrosive Environments in Power Plants
- Food and Beverage Processing Areas
- Mining Operations
- Transportation Facilities
- Storage and Containment Areas

**WANT TO FIND OUT MORE?**

**SCAN QR CODE**  
TO VIEW FULL FRP PULTRUDED  
DECKING BROCHURE

CLICK TO VIEW





## PRODUCT RANGE | PULTRUDED DECKING

Discover the versatility and durability of our FRP pultruded decking profiles, designed to meet the highest standards of performance and safety. Please refer to the tables below for an overview of our FRP pultruded decking profiles, showcasing the diverse sizes, available to suit a wide range of applications.



**FL-A DECKING**

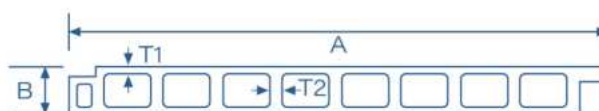

TYPE	TOP WIDTH (mm)	OVERALL WIDTH (mm)	DEPTH (mm)	WEIGHT (kg/m)	SURFACE FINISH
FL-A DECK	482.6	508	50.8	19.7	Silicon Grit



**STANDARD DECKING**

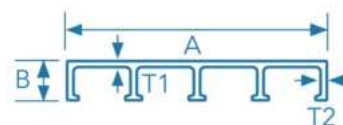

TYPE	TOP WIDTH (mm)	DEPTH (mm)	WALL THICKNESS (mm)	WEIGHT (kg/m)	SURFACE FINISH
DECK250x32x5	250	32	5	4.5	Silicon Grit
DECK250x40x6	250	40	6	5.3	Silicon Grit



**FLOOR PLATE**

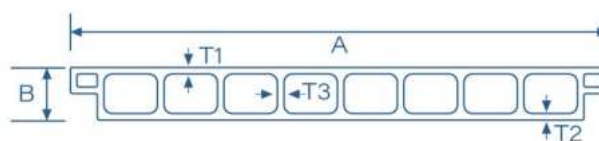

TYPE	TOP WIDTH (mm)	DEPTH (mm)	BOTTOM WIDTH (mm)	WEIGHT (kg/m)	SURFACE FINISH
FP500-50 (Light)	500	48.5	450	16.4	Silicon Grit
FP500-50	600	48.5	550	18.5	Silicon Grit
FP725-45	725	45	675	17.9	Silicon Grit



# COMPOSITE FASTENERS

18

Introducing our FRP Composite Fasteners, designed for superior strength, corrosion resistance, and durability in challenging environments. These lightweight, non-conductive fasteners are the ideal alternative to traditional metal options, ensuring long-lasting performance across various applications.

## APPLICATIONS

FRP Composite Fasteners are versatile solutions designed to meet the demands of a wide range of applications. Ideal for use in construction, marine, and industrial settings, these fasteners excel in environments where corrosion resistance, lightweight strength, and durability are crucial. These include:

- Aerospace and Aviation Components
- Marine and Offshore Structures
- Wind Turbine Assemblies
- Chemical Processing Equipment
- Automotive and Transportation
- Railway and Subway Systems
- Construction and Infrastructure Projects
- Electrical and Electronic Enclosures
- Water and Wastewater Treatment Plants
- Defense and Military Equipment
- Sporting Goods Manufacturing
- Telecommunication Towers

## WANT TO FIND OUT MORE?

**SCAN QR CODE**  
TO VIEW FULL COMPOSITE  
FASTENER BROCHURE

CLICK TO VIEW



## PRODUCT RANGE | COMPOSITE FASTENERS

Our product range features high-quality fasteners engineered to deliver exceptional performance in demanding environments. From bolts and nuts to washers and threaded rods, each product in our range is designed for superior strength, corrosion resistance, and longevity.



**THREADED ROD**

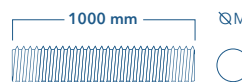

SIZE	AVAILABILITY	LENGTH (mm)	COLOUR
M10	To Order	As Required	LIGHT GREEN
M12	Std Stock Item	1000	LIGHT GREEN
M16	Std Stock Item	1000	LIGHT GREEN
M20	Std Stock Item	1000	LIGHT GREEN
M24	To Order	1000	LIGHT GREEN



**COMPOSITE BOLTS**

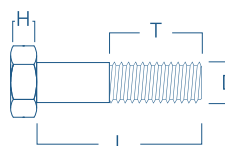

SIZE	AVAILABILITY	BOLT LENGTH 'L' (mm)	THREAD LENGTH 'T' (mm)	HEX HEAD 'H' (mm)	COLOUR
M10	To Order	As Required	As Required	10	LIGHT GREEN
M12	To Order	As Required	As Required	12	LIGHT GREEN
M16	To Order	As Required	As Required	16	LIGHT GREEN
M20	To Order	As Required	As Required	20	LIGHT GREEN
M24	To Order	As Required	As Required	24	LIGHT GREEN



**HEX NUTS**

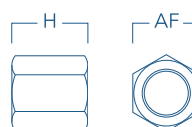

SIZE	AVAILABILITY	LENGTH 'H' (mm)	HEX HEAD 'H' (mm)	COLOUR
M10	To Order	N/A	N/A	LIGHT GREEN
M12	Std Stock Item	20	24	LIGHT GREEN
M16	Std Stock Item	25	32	LIGHT GREEN
M20	STD Stock Item	32	40	LIGHT GREEN
M24	To Order	N/A	N/A	LIGHT GREEN



**FLAT WASHERS**

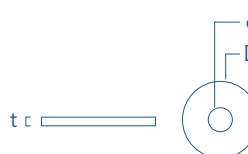

SIZE	AVAILABILITY	EXTERNAL DIAMETER 'D' (mm)	INTERNAL DIAMETER 'd' (mm)	COLOUR
M10	To Order	N/A	N/A	LIGHT GREEN
M12	Std Stock Item	25	13	LIGHT GREEN
M16	Std Stock Item	32	17	LIGHT GREEN
M20	STD Stock Item	36	21	LIGHT GREEN
M24	To Order	N/A	N/A	LIGHT GREEN

# FIBRE FRAME

20



Step into the future of decking with GRP Australia's Fibre Frame System, designed using high-performance Fiber Reinforced Polymer (FRP). Engineered to replicate the spans of traditional hardwood, our system delivers exceptional strength, durability, and resistance to the harshest weather conditions. Additionally, its lightweight design simplifies installation, and its low-maintenance properties keep your deck looking great with minimal effort.

## APPLICATIONS

Our Fibre Frame outdoor sub-structure system excels in wet, humid, and corrosive environments, offering unmatched durability and resistance to rot, rust, and chemical exposure. Ideal for coastal regions and moisture-prone areas, Fibre Frame provides a long-lasting, maintenance-free foundation for outdoor structures. These include:

- Coastal Decking and Boardwalks
- Swimming Pool Surrounds and Platforms
- Wetland Walkways and Nature Trails
- Rooftop Terraces and Green Roofs
- Rainforest or Tropical Region Structures
- Aquaculture Farms
- Coastal Home Decks & Patios
- Garden Walkways & Bridge
- Jetties & Pontoons
- Infrastructure in Flood-Prone Areas



## PRODUCT RANGE | PROFILES

Our range of FRP posts, bearers, and joists are engineered to provide unparalleled strength, durability, and performance in decking applications. Designed for use in both residential and commercial settings, these components offer a modern, maintenance-free alternative to traditional timber, ensuring a stable and long-lasting foundation for your decking.



**BEARERS / JOISTS**

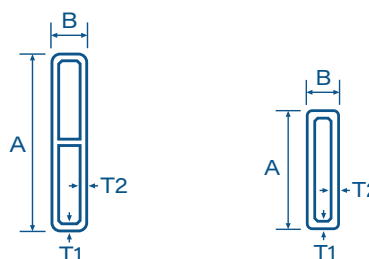

TYPE	DIMENSIONS (mm)	LENGTHS AVAILABLE (mm)			Weight (kg/m)
FF200x50	200 x 50 x 8 x 5	6050	3620	2420	5.6
FF140x45	140 x 45 x 6 x 4	6050	3620	2420	3
FF120x45	120 x 45 x 6 x 4	6050	3620	2420	2.8
FF90x45	90 x 45 x 5 x 4	6050	3620	2420	2.1



**POSTS**

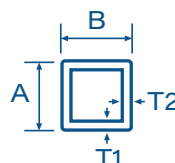

TYPE	DIMENSIONS (mm)	LENGTHS AVAILABLE (mm)	Weight (kg/m)
FF100x100	100 x 100 x 8 x 8	5800	6
FF76x76	76 x 76 x 6.4 x 6.4	5800	4.9

## PRODUCT RANGE | END CAPS

Our premium range of End Caps offers the perfect finishing touch to your decking system, combining both aesthetic appeal and enhanced durability. Designed to seamlessly complement a variety of decking styles, these end caps ensure a clean, polished look by covering exposed edges and open ends.



**END CAPS**

TYPE	DESCRIPTION	PAIRED PROFILES
EC100100	End Cap 100 x 100	FF100x100
EC20050	End Cap 200 x 50 x 8 x 5	FF200x50
EC14045	End Cap 140 x 45 x 6 x 4	FF140x45
EC12045	End Cap 120 x 45 x 6 x 4	FF120x45
EC9045	End Cap 90 x 45 x 5 x 4	FF90x45

## 22 PRODUCT RANGE | BRACKETS

Our comprehensive range of brackets is specifically designed to seamlessly integrate with our FRP posts, bearers, and joists, ensuring a secure, stable, and durable decking structure. Engineered for maximum strength and ease of installation, these brackets are essential for creating a robust framework that supports your decking system's longevity and safety.



**FFAB10040**  
Angle Bracket  
100x40x2



**FFHB4590**  
Joist Hanger  
Bracket



**FFHB45140**  
Joist Hanger  
Bracket

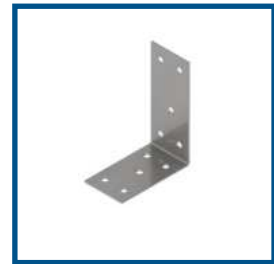

**FFPB01**  
Pergola Bracket



**FFPSB10045**  
Bearer to Post  
Side Bracket



**FFPSB10050**  
Bearer to Post  
Side Bracket



**FFSP190100**  
Splice Plate  
190 x 100



**FFSP250180**  
Splice Plate  
250 x 180

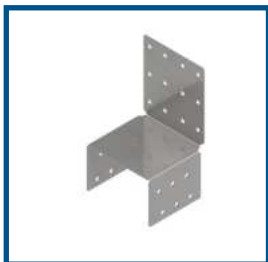

**FFPTB76**  
Post Top Bracket  
76



**FFPTB100**  
Post Top Bracket  
100



**FFTGRH**  
Triple Grip  
Right Hand



**FFTGLH**  
Triple Grip  
Left Hand



**10Gx25-G410-W**  
Self Drilling Screw

### FIXINGS

Our 10G x 25mm Wafer Head Self-Drilling Screws are specifically designed for securely fastening our FRP profiles, offering a reliable and efficient solution for assembling and reinforcing the Fibre Frame systems. These screws are an essential component for any project involving FRP materials, providing both strength and durability in demanding environments.



## WANT TO FIND OUT MORE

Thank you for exploring our product range. For more information, please scan the QR code to visit GRP Australia's website. We look forward to assisting you with your next FRP project.





**GRP AUSTRALIA**

**L:** 25 Shannon Place, Virginia 4014

**E:** [sales@grpaustralia.com.au](mailto:sales@grpaustralia.com.au)

**P:** 07 3252 1244

