

STÄRKE AMBIANCE SPECIFIERS GUIDE



FOREWORD

Welcome to the latest specifiers design guide for the Ambiance Inline Window System!

At STÄRKE, we are passionate about making it easy; it's just the way we do things. We wish to empower architects and specifiers with knowledge to allow them to explore their creativity, integrating high-performance window systems into their designs.

That is the driving force behind this new guide document. It contains a comprehensive overview of the detail in the STÄRKE Ambiance Inline Window System - everything from technical datasheets to design advice, certificates and reports.

We look forward to working with you to create warmer, drier and healthier homes throughout this beautiful country we live in.

For assistance, clarification, support or further details contact us directly at technical@starke.co.nz or phone us on 09 279 8617.

Yours sincerely,

Team STÄRKE





ABOUT STÄRKE

100%
Kiwi owned
and operated

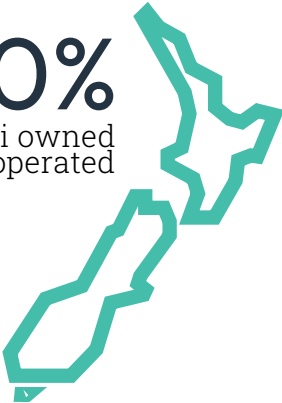

OVER
6000m²
manufacturing facilities
across multiple locations

40
years in
operation

END-TO-END
supply chain



70+
STAFF



2000
units per month capacity

CONTENTS

01

PRODUCTS

Tilt & Turn Window	8
Awning Window	10
Hinged Door	12
Entry Door	14
LiftSlide Door	16
SmartSlide Door	18
VarioSlide	20
Invisifold	22
Custom	23

02

INTERNAL FINISHING OPTIONS

Installation with Reveal	24
Installation with Fixing Tab	25

03

EXTERNAL FINISHING OPTIONS

Recessed Flashing Kit	26-27
Clip-in flange	27

04

HARDWARE ACCESSORIES 29

05

GLAZING

LightBridge Low-E	30
PermaTech Low-E	31
UV Protection	32
Acoustic	32
Tint / Clarity	32
Datasheets	33

06

COLOURS

Standard Colours	34
Special Colours	34

07

ADDITIONAL RESOURCES

Useful Links	36
STÄRKE Services	37

08

TECHNICAL SUMMARIES

Window R-Value Performance Guide	38-39
Durability	41
Scratch Resistance	42
NZS4211 Summary	43
Acoustic Test Report	44
Burglar Intrusions	45
Awning Size Matrix	46-47
Recycled Content	48
Product Technical Statement	50-53

09

APPENDIX

Engineering Judgement	55
Ambiance uPVC Sustainable Engineering Report	56-58
Thermal Calculations	59-65
Glass Spacer Report	66-68
Environmental Product Deceleration	69-86
Span Charts	87-99
Care & Maintenance	100
Warranty	101
BRANZ Appraisal	102



THE STÄRKE DIFFERENCE

STÄRKE Ambiance uPVC

UPVC FRAMES

Strong steel-reinforced uPVC frames to battle against heat transfer and outside noise

LOW-E GLASS

Insulating glass units to control heat loss and solar gain with maximum clarity

INTERNALLY BEADED

Protection from invaders and easy glazing from the inside

DUAL SEALING

Two sealing points which are co-extruded with the frame to prevent any air, water or sound leakage

CO-EXTRUDED GASKETS

Gaskets are co-extruded with the frame profile meaning no path for air, water or sound leakage

WELDED CORNERS

Factory welded corners preventing movement and sealing against air, water and sound leakage

SECURE HARDWARE

Premium multi-point locking hardware makes it burglar resistant





AMBIANCE INLINE WINDOW SYSTEMS

TILT & TURN WINDOW

ADVANTAGES

- ▶ Easily clean the outside pane from inside with the turn functionality
- ▶ Increased security with multiple locking points
- ▶ Better thermal performance and air-tightness than an awning or casement
- ▶ Larger windows available than awning
- ▶ Secure ventilation while you are out
- ▶ Highest rated sound insulation
- ▶ Lower maintenance and longer life expectancy than an awning, because the weight is not hanging on the fastenings

DESIGN ADVICE

- ▶ Best option for high performance builds because of the high air-tightness
- ▶ Ideal for second-storey windows, so the outside can be cleaned. Keep sill height above 1000mm so there is no fall risk.
- ▶ Tilt-only is ideal for large picture windows where ventilation is required
- ▶ Tilt-only is the most cost effective option
- ▶ Tilt-before-turn can be specified with a key to meet safety from falling NZBC F4
- ▶ Lowest maintenance option
- ▶ Open-in configuration requires wall-mounted curtains
- ▶ No raked opening sashes - the operable window must be square

TECHNICAL

 **70mm**
Construction depth

 **1.3 W/m²K**
Best U_f value

 **R 1.3 M2k/w**
Best R-value (TGU only)

 **Up to 44dB**
Sound insulation

 **1600w x 2400h**
Max Dimensions

 **R 0.74 M2K/w**
Average R-value

 **Passive House Recommended**

 **Up to RC2**
Burglar Resistance

 **Up to 41mm Glazing**
Double or Triple glazing

 **Category 4**
Airtightness



FEATURES

Dual opening function

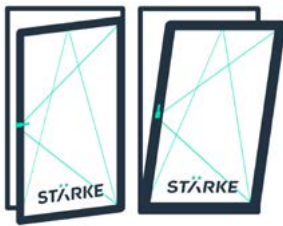

Multi-point locking



Secure venting



Double or triple glazing

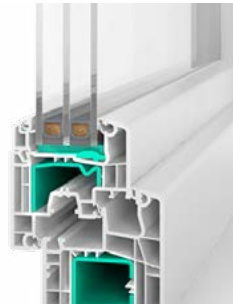

1033 Lever Handle

- ▶ Clean modern aesthetic
- ▶ Available in black or white
- ▶ Dual function with Tilt and Turn
- ▶ Added security with multiple locking points.



Cross Section

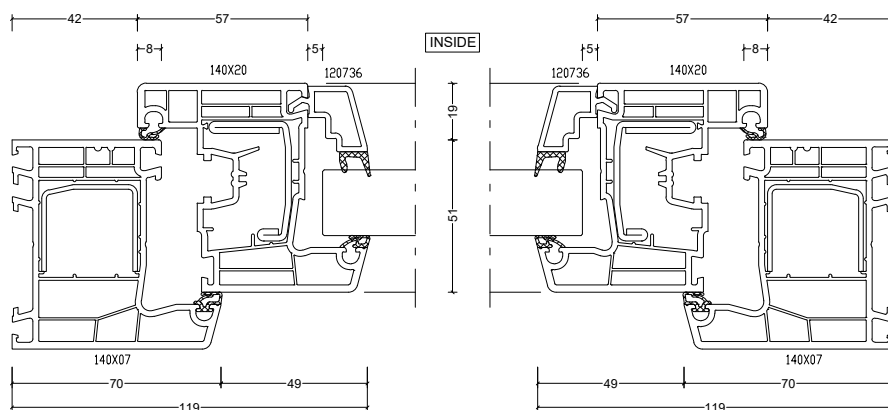



AMBIANCE INLINE WINDOW SYSTEMS

AWNING WINDOW

ADVANTAGES

- ▶ Traditional opening style in New Zealand
- ▶ Inferior performance to Tilt & Turn
- ▶ Enables secure ventilation with multi-point interior locking
- ▶ Can be locked in ventilating position
- ▶ More secure than an aluminium window
- ▶ Best used on smaller units
- ▶ Can pose a risk when opening onto passageways or decks

DESIGN ADVICE

- ▶ Best used for refurbishments or smaller windows
- ▶ Commonly used in more traditional builds
- ▶ Best used on builds where low cost is a primary factor
- ▶ No raked opening sashes - the operable window must be square

TECHNICAL

 **70mm**
Construction depth

 **1.3 W/m²K**
Best U_f value

 **R 1.3 M2k/w**
Best R-value (TGU only)

 **Up to 44dB**
Sound insulation

 **1400w x 1600h**
Max Dimensions
* Refer to awning size matrix

 **R 0.74 M2K/w**
Average R-value

 **Not Passive House Recommended**

 **Up to RC1**
Burglar Resistance

 **Up to 41mm Glazing**
Double or Triple glazing



FEATURES

Multi-point locking



Secure venting



Welded corners

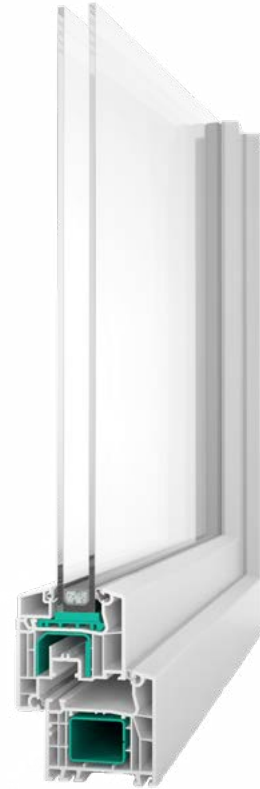

Vita Lever Handle

- ▶ Cranked design for easy use
- ▶ Available in black or white
- ▶ Secure locked ventilation
- ▶ Added security with multiple locking points.



Cross Section

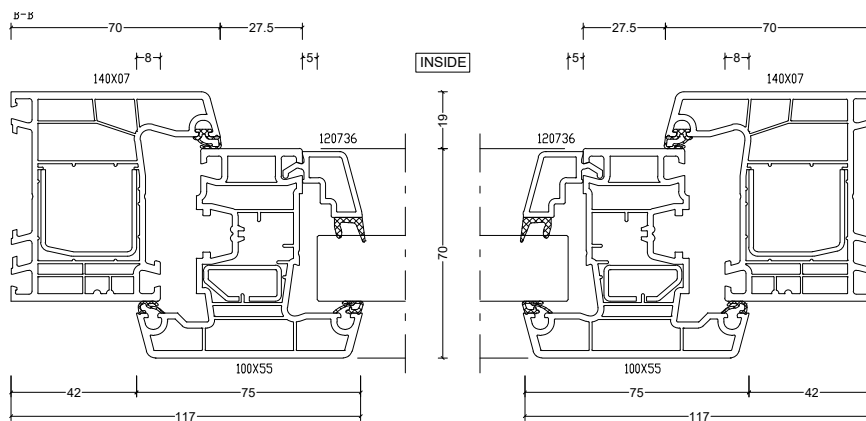



AMBIANCE INLINE WINDOW SYSTEMS

HINGED DOOR

ADVANTAGES

- ▶ Traditional opening style, can be used in a “French door” style
- ▶ Open in and open out configurations
- ▶ High air-tightness with multi-point locking
- ▶ Very high security
- ▶ Wide opening - provides 100% opening space
- ▶ Low maintenance with reliable hinges and locking mechanisms
- ▶ Recommend for Passive House designs

DESIGN ADVICE

- ▶ Recommended for service doors or laundry doors
- ▶ Low-height sill option
- ▶ High air-tightness makes for the best option for Passive House.
- ▶ Can be paired with side-lights for secure ventilation
- ▶ Multi-point locking available
- ▶ Open in is recommended as a Tilt & Turn
- ▶ Parliament hinge option for brick veneer cladding

TECHNICAL

 **70mm**
Construction depth

 **1.3 W/m²K**
Best U_f value

 **R 1.3 M2k/w**
Best R-value (TGU only)

 **Up to 44dB**
Sound insulation

 **1200w x 2600h**
Max Dimensions

 **R 0.74 M2K/w**
Average R-value

 **Passive House Recommended**

 **Up to RC2**
Burglar Resistance

 **Up to 41mm Glazing**
Double or Triple glazing



FEATURES

Low threshold option

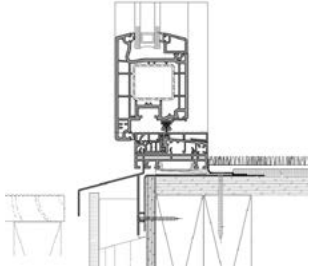

Digital lock - ELOK



French door configuration



Multi-point locking

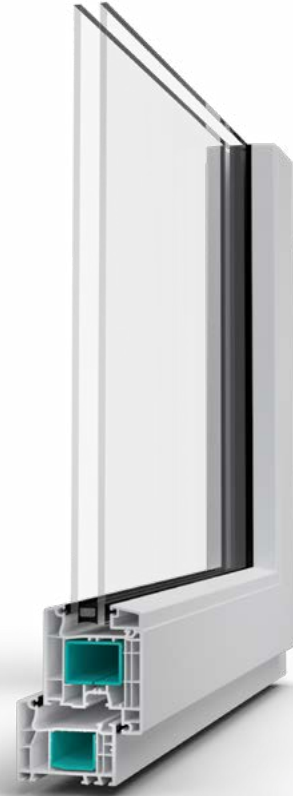

1033 Lever Handle

- ▶ Clean modern aesthetic
- ▶ Available in black or white
- ▶ Added security with multiple locking points
- ▶ Multiple key and snib configurations



Cross Section

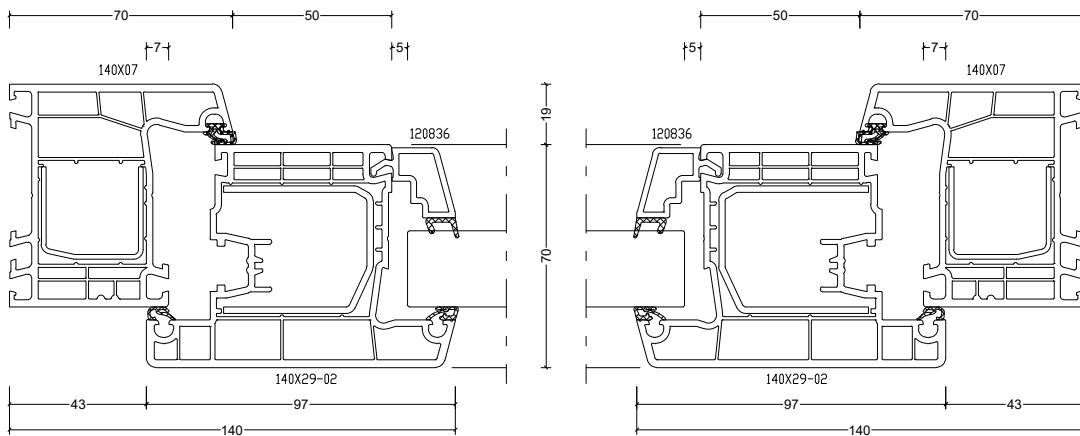



AMBIANCE INLINE WINDOW SYSTEMS

ENTRY DOOR

ADVANTAGES

- ▶ Glazing, frosted, full panel, or panel with transom/mullion options
- ▶ 40mm composite panel can be glazed into the sash
- ▶ 50mm composite/aluminium/timber panel can be mounted directly to frame
- ▶ Large range of design options and colours to suit every taste available.

DESIGN ADVICE

- ▶ Sheltered installation preferred - away from full sun exposure and driving rain
- ▶ A large range of configurations available
- ▶ Equivalent R-values of standard doors achieved
- ▶ Peep holes can be incorporated
- ▶ Side-lights are a common design feature
- ▶ 40mm glazed-in sash panels have full multi-locking and air-tightness, but are limited to E-LOK electronic locks
- ▶ 50mm hinged-in panels have single-point locking, worse air-tightness, all lock options but come at an extra cost.
- ▶ Parliament hinge option for brick veneer cladding

TECHNICAL

 **70mm**
Construction depth

 **1.3 W/m²K**
Best U_f value

 **R 1.3 M2k/w**
Best R-value (TGU only)

 **Up to 44dB**
Sound insulation

 **1100w x 2600h**
Max Dimensions

 **R 0.74 M2K/w**
Average R-value

 **Passive House Recommended**
(glazed-in panels only)

 **Up to RC2**
Burglar Resistance

 **Up to 41mm Glazing**
Double or Triple glazing



FEATURES

Digital lock - ELOK



Configurable

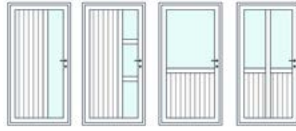

Low sill option

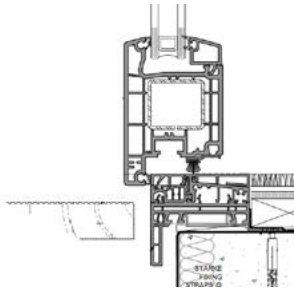

Offset French panel option

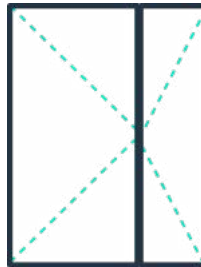

1033 Lever Handle

- ▶ Clean modern aesthetic
- ▶ Available in black or white
- ▶ Added security with multiple locking points
- ▶ Multiple key and snib configurations



Cross Section

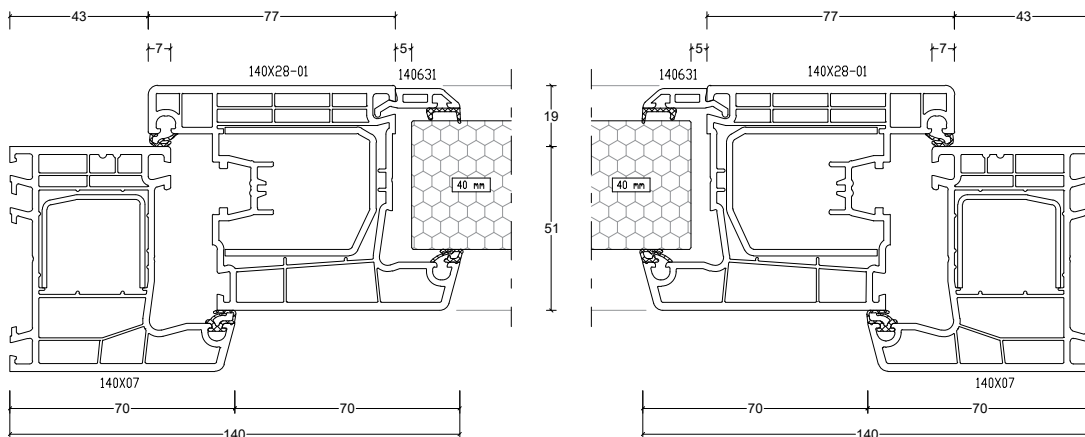



AMBIANCE INLINE WINDOW SYSTEMS

LIFTSLIDE DOOR

ADVANTAGES

- ▶ Fully flush sill, barrier free entry possible
- ▶ Air-tightness level suitable for Passive House
- ▶ Opened and closed without effort even with extra large door panel sizes
- ▶ Suitable for double or triple glazing

DESIGN ADVICE

- ▶ Most luxurious door in the STÄRKE Ambiance Range
- ▶ Recommended for projects with high air-tightness requirements such as Passive House
- ▶ Sliding and bi-parting configurations only
- ▶ Rebate the sill for perfectly flush entry

TECHNICAL

 **200mm**
Construction depth

 **1.1 W/m²K**
Best U_f value

 **R 1.3 M2k/w**
Best R-value (TGU only)

 **Up to 44dB**
Sound insulation

 **1700w x 1975h**
Min Dimensions

 **0.63 W/m²K**
Best U_w value

 **Passive House Recommended**

 **3000mm**
Max panel width



FEATURES

Flush sill



Large panels



Air-tight frame

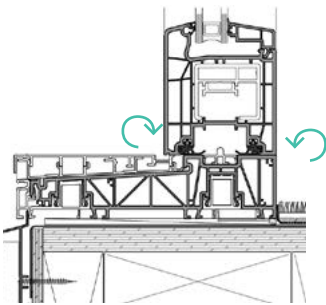

Smooth sliding



Siegenia

- ▶ Available in black or white
- ▶ Lever handle operates the sealing function
- ▶ Added security with multiple locking points
- ▶ Multiple key and snib configurations
- ▶ Flush pull option on the outside



Cross Section

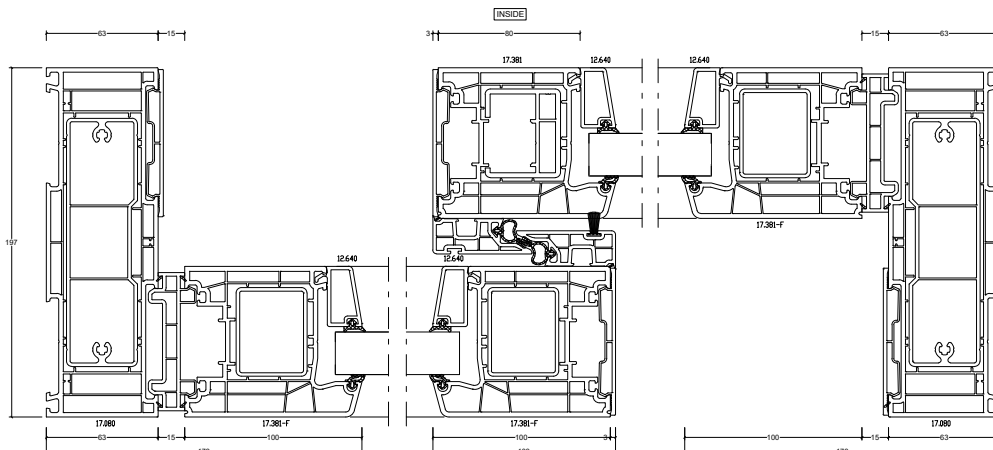



AMBIANCE INLINE WINDOW SYSTEMS

SMARTSLIDE DOOR

ADVANTAGES

- ▶ SmartSlide technology allows high air-tightness
- ▶ Large panel openings available
- ▶ Best-selling sliding door system
- ▶ Smart sliding hardware enables silent free-gliding movement
- ▶ Sliding or Bi-parting configurations available
- ▶ Hardware allows secure locked venting function for passive airflow

DESIGN ADVICE

- ▶ Most cost-effective high air-tightness door, suitable for Passive House.
- ▶ Recommend no more than two doors for Passive House
- ▶ Large panel sizes available
- ▶ Suitable for SED wind zones
- ▶ Sliding panel to be at least 100mm wider than the height

TECHNICAL

 **140mm**

Construction depth

 **1.3 W/m²K**

Best U_f value

 **R 1.3 M2k/w**

Best R-value (TGU only)

 **Up to 44dB**

Sound insulation

 **5800w x 2640h**

Max Overall Dimensions

 **R 0.74 M2K/w**

Average R-value

 **Passive House Recommended**

 **2000w x 2640h**

Max Panel Dimensions

 **Up to RC2**

Burglar Resistance

 **Up to 41mm Glazing**

Double or Triple glazing

 **1500w x 700h**

Min Overall Dimensions



FEATURES

Secure venting

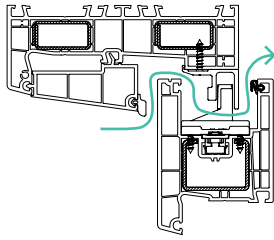

Smooth sliding



Air-tight frame

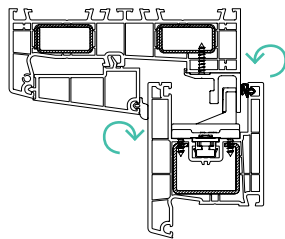

Multi-point locking



Maco Move

- ▶ Available in black or white
- ▶ Lever handle operates the sealing function
- ▶ Added security with multiple locking points
- ▶ Multiple key and snib configurations
- ▶ Flush pull option on the outside



Cross Section

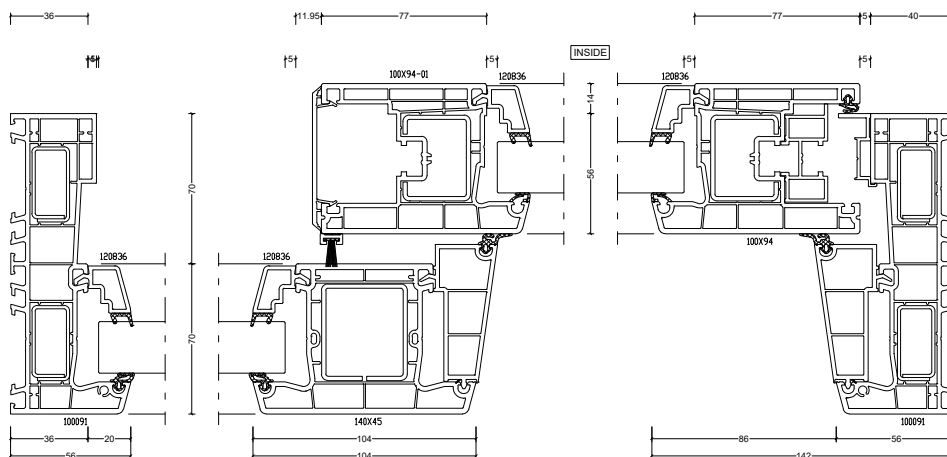



AMBIANCE INLINE WINDOW SYSTEMS

VARIOSLIDE

ADVANTAGES

- ▶ Stackers and Sliders available
- ▶ Great for large openings and indoor-outdoor flow
- ▶ Cost-effective entry-level door with high thermal performance
- ▶ Most similar to a traditional aluminium sliding door

DESIGN ADVICE

- ▶ Stacking or sliding doors available, including 4- or 6-panel bi-parting doors
- ▶ No awnings available in fixed pane
- ▶ Can be rebated for flush entry
- ▶ Recommended 140mm framing for all stackers
- ▶ Recommended 90mm framing for all sliders

TECHNICAL

 **70mm/125mm**

Construction depth
(Slider/Stacker)



1.3 W/m²K

Best U_f value



Very High

Max Wind Zone



Up to 35dB

Sound insulation



5800w x 2400h

Max Overall Dimensions



R 0.74 M2K/w

Average R-value



**Not Passive House
Recommended**



1500w x 2400h

Max Panel Dimensions



Up to RC1

Burglar Resistance



Up to 41mm Glazing

Double or Triple glazing



1200w x 700h

Min Overall Dimensions



FEATURES

Multi-point locking



Awning sidelight



Rebated sill

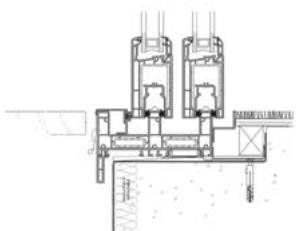

Stacker



1033 Lever Handle

- ▶ Available in black or white
- ▶ Added security with multiple locking points
- ▶ Multiple key and snib configurations
- ▶ Flush pull option on the outside



Cross Section

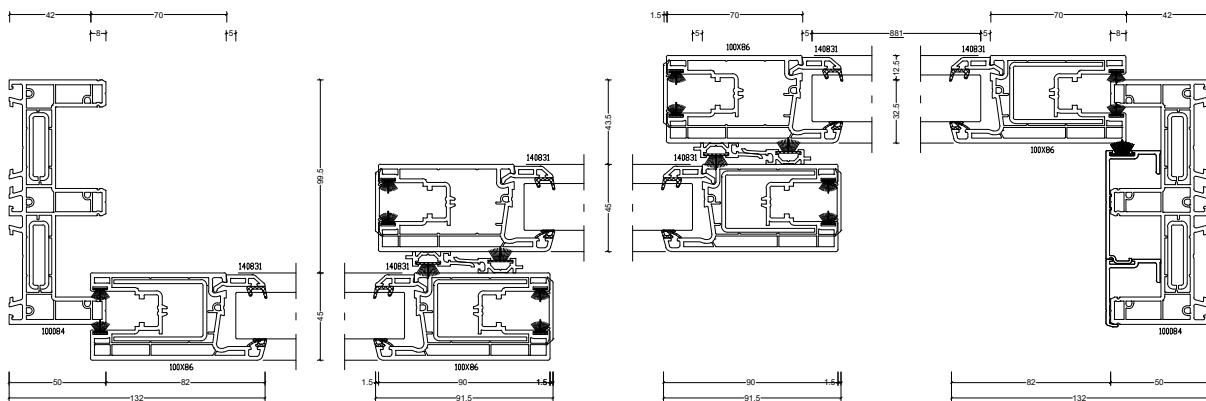



AMBIANCE INLINE WINDOW SYSTEMS

INVISIFOLD

ADVANTAGES

- ▶ Each panel operates individually reducing the load on the other panels
- ▶ All panels stack in one direction
- ▶ First panel is hinged opening and can be used as a single door
- ▶ Can open a few panels only - don't have to open all at once
- ▶ Easy operation

DESIGN ADVICE

- ▶ Open out operation
- ▶ Average panel size of 800mm - 900mm
- ▶ The wind zone will affect the panel width
- ▶ Cross sections are similar to Open Out Hinged Door
- ▶ Consider Smartslide or LiftSlide if higher air-tightness is required

TECHNICAL

 **70mm**
Construction depth

 **1.3 W/m²K**
Best U_f value

 **Very High**
Max Wind Zone

 **Up to 35dB**
Sound insulation

 **5800w x 2400h**
Max Overall Dimensions

 **R 0.63 M2K/w**
Average R-value

 **Not Passive House Recommended**

 **Enquire**
Max Panel Dimensions

 **Up to RC1**
Burglar Resistance

 **Up to 24mm Glazing**
Double glazing





AMBIANCE INLINE WINDOW SYSTEMS

CUSTOM UNITS

ADVANTAGES

- ▶ Custom shapes and sizes available
- ▶ Coupled units available with all systems
- ▶ Allows greater flexibility to design special items to compliment your design

DESIGN ADVICE

- ▶ Raking units a minimum angle of 30 degrees
- ▶ Maximum of 5 corners per window for raking units
- ▶ Take into account the profile width when coupling units
- ▶ Wind beams or lintels provide a good solution to overcome deflection for larger units

TECHNICAL

 **85mm**
Construction depth

 **Enquire**
Max panel width

 **Up to RC2**
Safety

 **1.1 W/m²K**
Best U_f value

 **0.63 W/m²K**
Best U_w value

 **Up to 44dB**
Sound insulation

INTERNAL FINISHING OPTIONS

INSTALLATION WITH REVEAL

Installation with a timber liner is the traditional window installation method in New Zealand. This method includes a pre-primed 18mm timber reveal, fitted to the window in the factory.

TWO SECURE FIXING POINTS

Historically, this timber liner is only stapled to the aluminium frame, however with our Ambiance uPVC system, the liner is fixed through the frame with a nail at regular intervals, in addition to staples. Also, steel fixing tabs - which clip into the frame - are fitted and fixed with screws into the back of the timber liner. This provides a very secure fixing of the liner to the frame, as it should be.

AIR-TIGHT TAPE

Additionally, we apply a premium air-tight tape around the entire perimeter of the frame, overlapping the window frame and timber liner. This means there is no air leakage at all between the liner and frame - a high-performance solution directly from the factory.

After the window is fixed into the building wall framing, PEF rod is inserted in the cavity then sealed in place with a unbroken bead of wet seal product. This completes the internal installation of the Ambiance window and provides a high-performance, air-tight solution superior to other mainstream products available in New Zealand currently.

This allows for:

- ▶ Grooved liners for plasterboard return
- ▶ Flat liners for finishing with an architrave

Grooved Liners

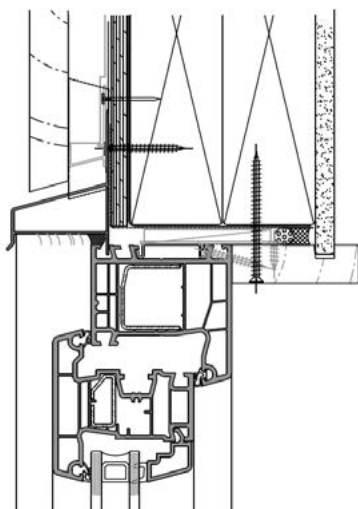

Architrave

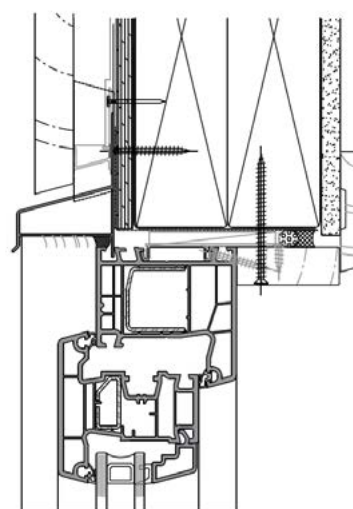

INSTALLATION WITH FIXING TAB

Installation with fixing tabs is a more flexible option for the internal finishing options available. No timber reveals are supplied, instead steel fixing tabs are clipped into the frame in the factory ready for installation. The fixing tabs can be trimmed onsite to the correct length, depending of the wall framing depth.

FLEXIBLE INTERNAL FINISHING OPTIONS

No timber reveals are supplied from the factory with this method. This allows you to design and specify the best option to suit your clients requirements. This includes allowance for a plasterboard return option or tiles directly up to the window frame. Reveals can also be used with this fixing method. When installed, the internal finishing should cover the tape overlapping the frame at least and do so without puncturing the tape. It is also possible to bring the internal finishing in to cover the whole frame depth, making for a minimalist frame appearance.

AIR TIGHT TAPE

Air-tightness tape is supplied in rolls with each window delivery. This is to be installed to cover the window frame by 10mm and the rest overlapping onto the building framing. It is to be fitted after the window is installed and ensures a completely air-tight dry installation. It is important this tape is fitted after the window is fixed in place and completely covers the entire steel fixing tab.

This allows for more flexibility with the internal finishing, including:

- ▶ Plasterboard/tile return
- ▶ Grooved liners for plasterboard return
- ▶ Flat liners for finishing with an architrave

PLANTED LINERS

This allows for the same finishing options as installation with reveal method

Grooved Liners

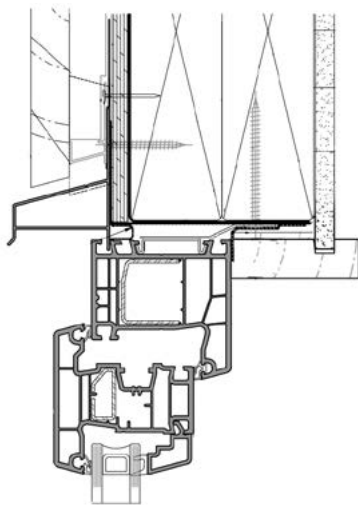

Architrave

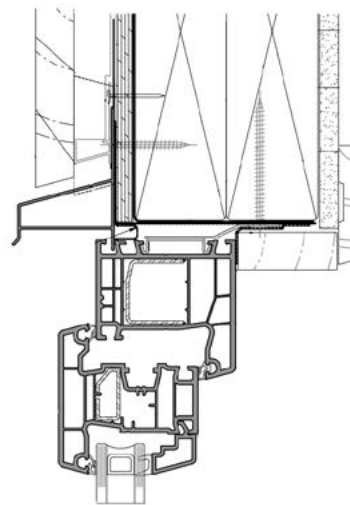

EXTERNAL FINISHING OPTIONS

RECESSED FLASHING KIT

Recessing your windows into the building framing has long been proven to get the most out of the thermal performance of the frames - this is just basic building science. The key point is connecting the wall insulation with the window insulation: a recessed window install.

Ambiance uPVC windows and doors have a high thermal performance value for joinery that is available in the mainstream building supplies market in New Zealand and with volume supply capability.

Included with the Ambiance uPVC Inline Window System is a 4-sided flashing system, covering the perimeter of the window externally on the head, sill and jambs. This cleanly covers the external cavity and cladding, in a simple way making installation easy.

This kit is designed to cover the cavity and cladding to protect the cavity from rain, and to provide an aesthetic, functional and easy recessed installation.

- ▶ Available in different sizes for different cavity and cladding applications
- ▶ 4-sided (head, jamb & sill) flashing kit
- ▶ Proprietary design - extruded aluminium and powder coated to match the uPVC joinery colour
- ▶ Built-in leg which slots into groove in the uPVC profile

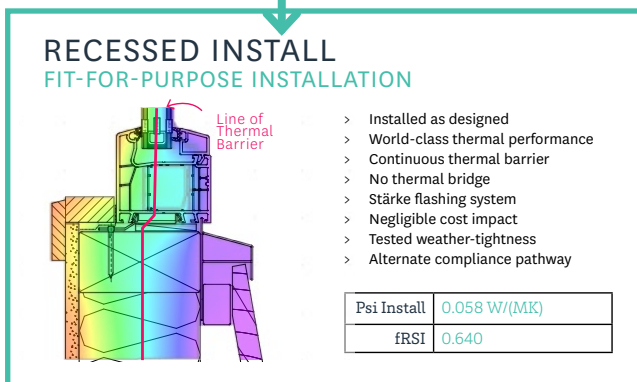
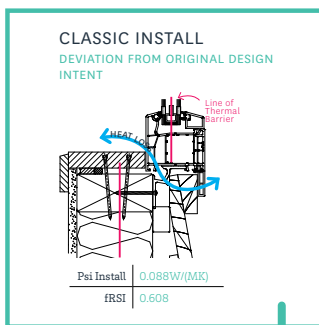



FLASHING KIT SIZES

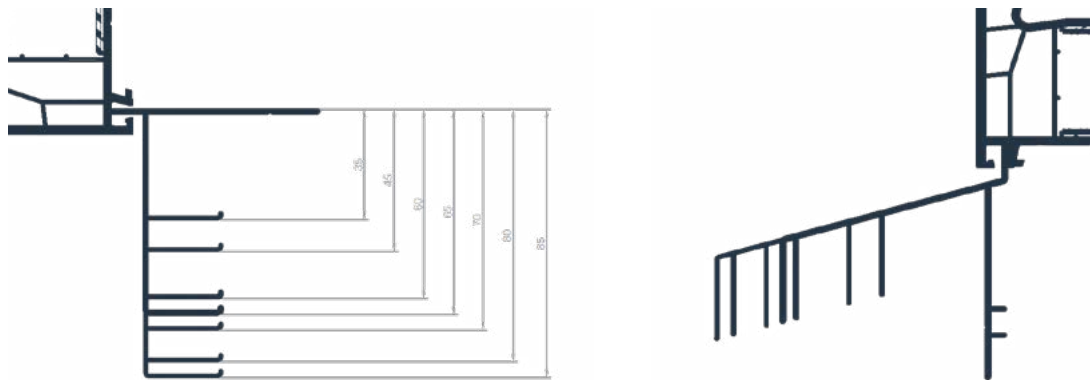

FLASHING KIT SIZES	RECOMMENDED CLADDING DIMS	SOME TYPICAL APPLICATIONS
35mm	25 to 29mm	19 Cavity & 9mm Sheet -OR- 19 Cavity & Folded Metal Cladding
45mm	35 to 39mm	19 Cavity & 19mm Sheet -OR- 19 Cavity & Rusticated Weatherboard
60mm	50 to 54mm	19 Cavity & Bevel-Back Weatherboard -OR- 45 Cavity & 9mm Sheet
65mm	55 to 59mm	50 Cavity & 70 Brick -OR- 45 Cavity & Folded Metal Cladding
70mm	60 to 69mm	45 Cavity & 19mm Sheet -OR- 45 Cavity & Rusticated Weatherboard
80mm	70 to 74mm	19 Cavity & Bevel-Back Weatherboard with Facings
85mm	75 to 79mm	45 Cavity & Bevel-Back Weatherboard

CLIP IN FLANGE

A 30mm or 50mm clip in uPVC flange is also available. Typical uses for this are:

- ▶ On the sill only for doors and windows where the window frame is on the floor
- ▶ Renovations and retro-fit projects
- ▶ Standard E2/AS1 install (not recommended by STÄRKE as this compromises the thermal performance of the frame)

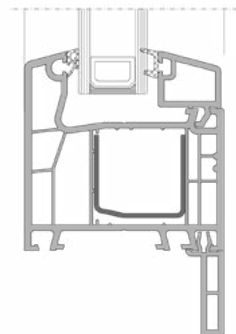



HARDWARE ACCESSORIES

RESTRICTOR STAYS

- ▶ Restricts the window opening to 100mm
- ▶ Stainless Steel
- ▶ Fully concealed design



HOLD BACKS

- ▶ Wall and floor mounted options
- ▶ Coloured to match joinery or any powder coat colour
- ▶ Short or long throw options
- ▶ Easy to install



DOOR VIEWER

- ▶ Wide viewing angle
- ▶ One-way viewing for security



WINDOW ACTUATORS

- ▶ Available in black and white
- ▶ Controllable by a physical switch or automation system
- ▶ Compatible with awning and Tilt-only windows



CONCEALED WINDOW ACTUATORS

- ▶ Includes multi-point locking control
- ▶ Fully concealed installation
- ▶ Controllable by a physical switch or automation system
- ▶ Compatible with Tilt & Turn and Tilt-only windows



COLONIAL / GEORGIAN BARS

- ▶ Colour matched uPVC profile
- ▶ Includes rubber gaskets
- ▶ Strong application for long life
- ▶ Applied on the external faces of the glass

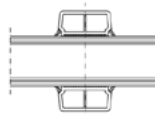

LOW-E GLAZING

LIGHTBRIDGE 1.1™

LightBridge 1.1™ is a low-e coating supplied by Viridian Glass for double and triple glazed units.

This glass is designed to allow heat from the sun to enter your home for warmth and retain it inside.

APPLICATIONS

- ▶ Residential homes
- ▶ Walk-ups and townhouses
- ▶ Residential apartments

SPACER

All LightBridge 1.1 glass units contain a thermally improved spacer bar and argon gas.

DESIGN CONSIDERATIONS

- ▶ Maximum size: 4500mm x 2700mm (varies with glass type and thickness)
- ▶ Internal gem bars are not compatible with low-e glass, consider external colonial bars if required
- ▶ In warmer areas, consider specifying LightBridge to the south and east elevations to maximise the heat from the sun.
- ▶ Available in clear, grey tint and EtchLite obscure options



PERFORMATECH™

PerformaTech is a low-e coating supplied by Viridian Glass for double and triple glazed units.

This glass is designed to restrict heat from the sun entering your home to assist with overheating, and retain heat generated inside.

APPLICATIONS

- ▶ Residential homes
- ▶ Walk-ups and townhouses
- ▶ Residential apartments
- ▶ Commercial

SPACER

All PerformaTech glass units contain a thermally improved spacer bar and argon gas.

DESIGN CONSIDERATIONS

- ▶ Maximum size: from 3300mm x 2140mm to 4500mm x 2700mm (varies with glass type and thickness)
- ▶ Internal gem bars are not compatible with low-e glass, consider external colonial bars if required
- ▶ In warmer areas, consider specifying PerformaTech to the north and west elevations to assist with preventing overheating
- ▶ This glass allows 35% of the sun's heat through, so extra heating may be required in winter if PerformaTech is used
- ▶ External solar shading is the most effective way to combat overheating in summer
- ▶ Available in clear, grey tint and EtchLite obscure options



GLAZING OPTIONS

UV PROTECTION

Tdw-ISO is the measure of damaging light wavelengths that can pass through the glass. While all wavelengths on the spectrum contribute to fading, some do more damage than others, such as UV light. Tdw-ISO is a weighted measure to account for this and provide an accurate result.

Tdw-ISO is measured relative to a standard clear/clear DGU which has a Tdw-ISO of 0.73. So, a laminated DGU with a Tdw-ISO of 0.57 is about 57% better at protecting interior furnishings than a clear/clear DGU.

Laminated glass is the best option to consider to protect interior furnishings from fading.

ACOUSTIC

STC Rating (Sound Transmission Class) is the measure of the glass ability to reduce sound penetrating through it. The higher the rating, the better the glass is at preventing sound passing through it. The STC Rating ranges from 25 (no soundproofing) to 65 (completely soundproof).

A single glazed window has an STC of around 25, a standard double glazed window will often be around 33-35.

Laminated glass is the best option to increase the STC of windows and doors.

TINT / CLARITY

Visible Light Transmission (VLT) is a measure, as a percentage, of how much light passes through the glass.

With no glass, there will be a VLT of 100%, therefore an IGU with a VLT of 80% will let through 80% of the outside light.

Grey tint is a popular option to include for aesthetics, however it significantly reduces the amount of light able to enter a room. Tinted glass, contrary to some thoughts, doesn't do much to reduce fading - for this, consider Low-E or laminated options.

Tinting the glass also reduces the solar heat gain (g value), however, this can be an artificial benefit as the glass itself heats up and then radiates this heat into the room.



GLASS DATASHEETS

LOW-E ON CLEAR

		Thickness	Ug	g	STC [dB]	Twd-ISO	VLT [%]	Rw
LightBridge	Double	4	1.119	0.59	30	0.65	79	0.74
		5	1.144	0.58	31	0.65	78	0.74
		6	1.269	0.57	31	0.63	77	0.74
	Triple	4	0.637	0.49	31	0.53	69	0.91
		5	0.674	0.49	34	0.53	68	0.91
		6	0.715	0.48	32	0.52	68	0.91
PerformaTech	Double	4	1.042	0.38	30	0.57	72	0.74
		5	1.068	0.38	34	0.53	71	0.74
		6	1.198	0.38	31	0.53	71	0.74
	Triple	4	0.590	0.31	30	0.43	59	0.91
		5	0.628	0.31	31	0.40	59	0.91
		6	0.671	0.30	31	0.40	58	0.91

LOW-E ON LAMINATE

		Thickness	Ug	g	STC [dB]	Twd-ISO [%]	VLT [%]	Rw
LightBridge	Double	4	1.14	0.56	35	0.54	78	0.74
		5	1.28	0.56	34	0.54	78	0.74
		6	1.26	0.55	38	0.54	77	0.74
	Triple	4	0.67	0.47	36	0.54	69	0.91
		5	0.67	0.47	36	0.45	68	0.91
		6	0.72	0.46	39	0.46	68	0.91
PerformaTech	Double	4	1.07	0.37	38	0.50	73	0.74
		5	1.19	0.38	38	0.47	72	0.74
		6	1.19	0.38	38	0.47	71	0.74
	Triple	4	0.63	0.31	38	0.39	59	0.91
		5	0.63	0.31	38	0.37	58	0.91
		6	0.67	0.31	39	0.37	58	0.91

LOW-E ON GREY TINT

		Thickness	Ug	g	STC [dB]	Twd-ISO [%]	VLT [%]	Rw
LightBridge	Double	4	1.119	0.41	32	0.40	50	0.74
		5	1.143	0.37	33	0.34	44	0.74
		6	1.269	0.34	33	0.29	39	0.74
	Triple	4	0.637	0.34	30	0.21	44	0.91
		5	0.674	0.30	34	0.28	37	0.91
		6	0.715	0.26	36	0.24	32	0.91
PerformaTech	Double	4	1.042	0.33	32	0.35	46	0.74
		5	1.068	0.30	33	0.28	41	0.74
		6	1.198	0.28	33	0.25	32	0.74
	Triple	4	0.590	0.31	30	0.27	38	0.91
		5	0.628	0.30	31	0.19	33	0.91
		6	0.670	0.30	31	0.19	29	0.91

KEY:

Ug Heat loss
g Heat gain

STC Acoustic
Twd-ISO Fading

VLT Visual clarity
Rw Average of the entire window with Ambiance uPVC frames

NOTES:

- ▶ LightBridge is applied to surface 3 on DGUs and 3 & 5 on TGUs
- ▶ PerformaTech is applied to surface 2 on DGUs and 2 & 4 on TGUs
- ▶ All glass panes in the IGU are the same thickness, except:
 - ▶ Laminated pane is 6.38mm
 - ▶ Centre pane in TGU is 4mm
- ▶ DGU total filling thickness is 24mm
- ▶ TGU total filling thickness is 40-41mm
- ▶ Spacer thickness is the total filling thickness minus the sum of all pane thicknesses
- ▶ Rw value is an average for a sample house lot with Ambiance uPVC frames and Low-E
- ▶ Spacer includes a thermally improved spacer bar and argon gas

COLOURS

STÄRKE Ambiance is available a variety of colours, and we keep stock in both black and white for shorter lead times and improved costs. Special colours can be ordered in on request and are available at a premium with extended lead times.

STANDARD COLOURS



BLACK

- ▶ RAL 9011
- ▶ Aludec lamination technology for UV and heat protection
- ▶ Powdercoat match: Flaxpod
- ▶ Profile coloured throughout



WHITE

- ▶ RAL 9016
- ▶ Powdercoat match: Appliance White
- ▶ UV protection
- ▶ Profile coloured throughout

SPECIAL COLOURS



Anthracite Grey

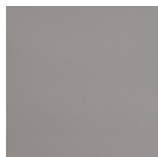

Window Grey

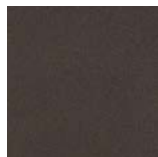

Umbra Grey



Basalt Grey

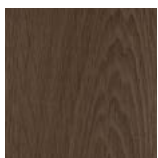

Turner Oak Toffee

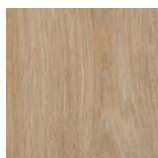

Turner Oak Malt

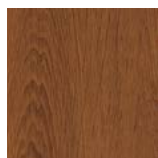

Turner Oak Walnut

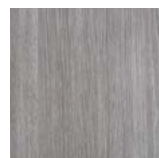

Sheffield Oak Concrete





USEFUL LINKS

MasterSpec Specification 4541 SU

masterspec.co.nz/Link-to-Masterspec-Result/6702-731db613-6a4b-49c0-9dbd-da5e0baeb272/



MasterSpec

All BIM Information

starke.co.nz/ambiance/specifiers-portal/

- ▶ PDF
- ▶ DWG
- ▶ REVIT
- ▶ ARCHICAD
- ▶ Cross sections, installation drawings



Ambiance Specifiers Portal

Working Spec 3D Installation Model

workingspec.me/models/sq-wfl-w70



Working Spec Model Library

STARKE ACADEMY – Blogs & Learning

starke.co.nz/ambiance/blog/



STARKE Blog

STÄRKE H1 Optimiser

starke.co.nz/ambiance/h1-calculator



STÄRKE H1 Optimiser

STÄRKE Knowledge Base

<https://starke.knowledgeowl.com/help>



STÄRKE Knowledge Base



STÄRKE SERVICES

STÄRKE is one of the only end-to-end joinery suppliers in New Zealand, which makes us uniquely placed to streamline your workflow, and provide high volume, high performance joinery on time and to specification.

We work with architects, engineers and specifiers from initial consultation, right through to pricing building partners, confirming specifications, and then fabrication, delivery and installation.

ARCHITECTURAL SUPPORT & DETAILING

- ▶ Design consultation
- ▶ Shop Drawings & PS1
- ▶ Samples boxes nationwide

TESTING & COMPLIANCE

- ▶ H1 compliance documentation via schedule, calculation or modelling method
- ▶ Support with council documentation & RFI
- ▶ Onsite or offsite joinery testing
- ▶ Blower door testing (coming soon)

EDUCATION & TRAINING

- ▶ Preliminary, budget and final pricing
- ▶ Architects Education, CPD accredited presentations
- ▶ Installation & after sales

FABRICATION & DISTRIBUTION

- ▶ Joinery fabrication

TECHNICAL SUMMARIES

The following R Value Performance Guide (as per NZBC H1/AS1 Table E.1.1.1) shows just how great the performance gap is between thermally broken aluminium and uPVC window frames – irrespective of the glazing specification.

WINDOW R-VALUE PERFORMANCE GUIDE

As per NZBC H1/AS1 Table 1.1.1

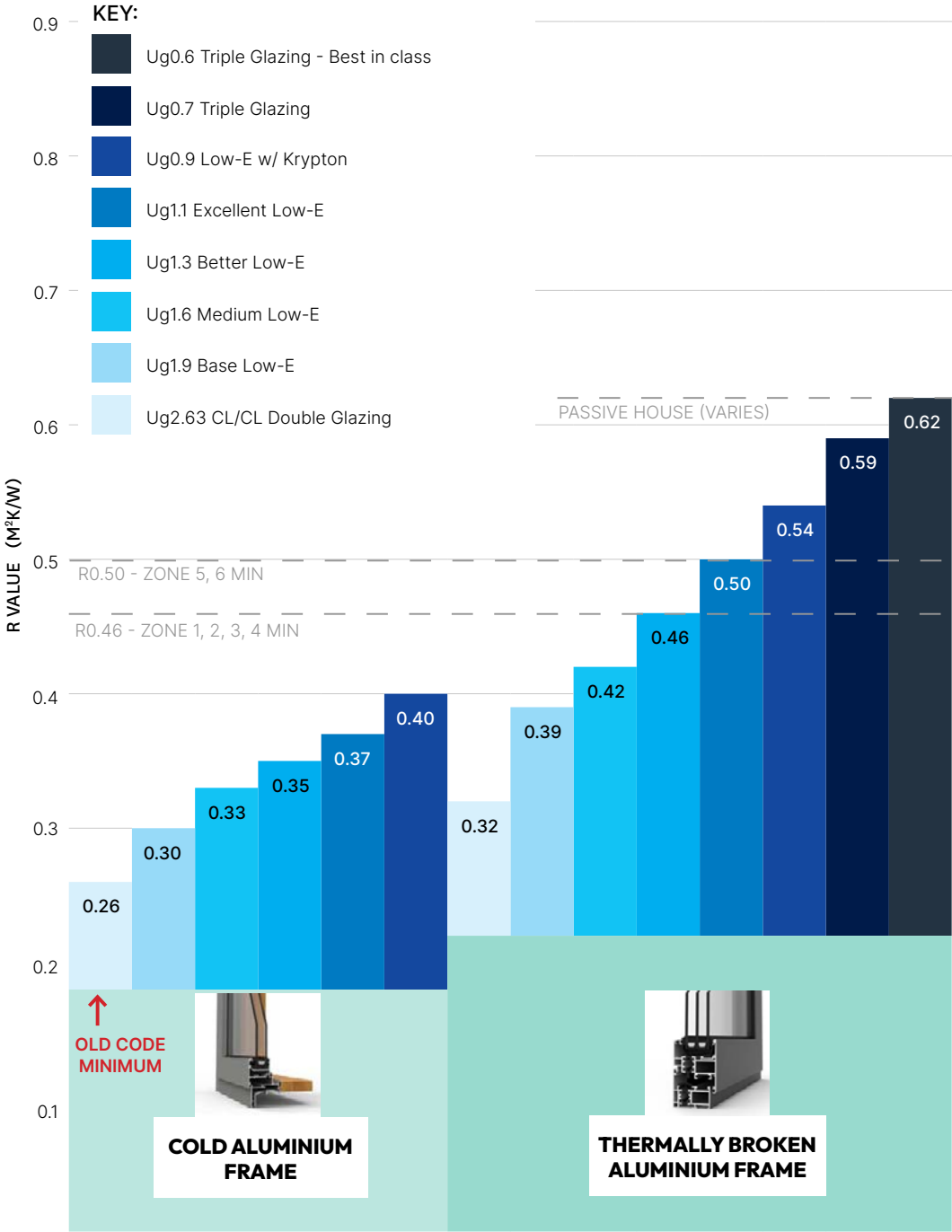

COPYRIGHT STARKE GROUP NOV 2023



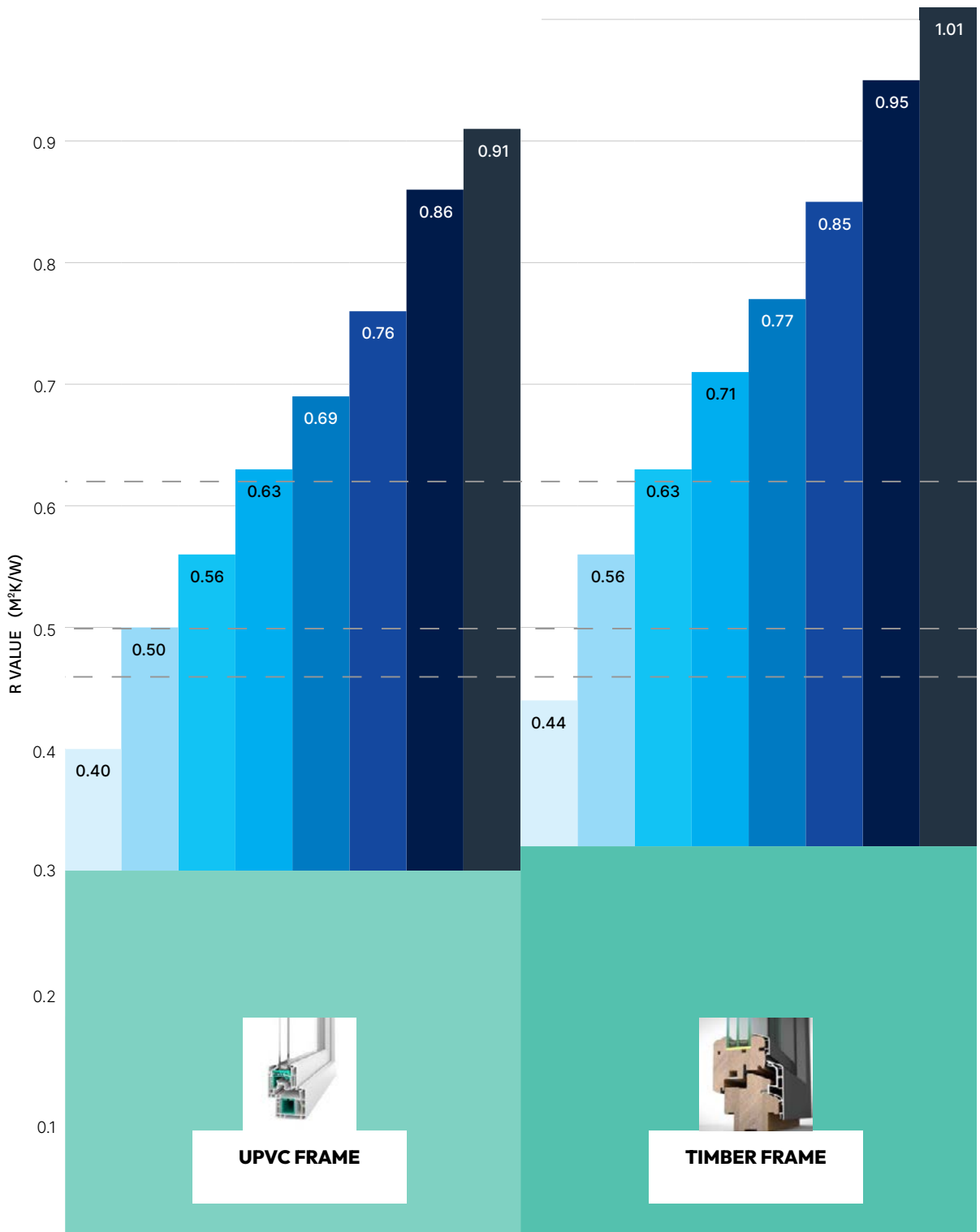



DURABILITY

New Zealand's diverse climate, ranging from the sunny North to the icy deep South, presents a huge durability challenge for most construction materials. When it comes to window frames, surviving in the face of varying temperatures, high humidity, and exposure to intense sunlight is paramount. In this context, uPVC (unplasticised polyvinyl chloride) emerges as a stand out material, offering exceptional performance for New Zealand homes.

WARRANTY

STÄRKE include a 10-year warranty period which serves as a commercial commitment to the durability of our uPVC window frames. Manufacturers typically offer this warranty to assure customers of the product's quality and performance, providing coverage for any unforeseen issues during the initial period of use. It should be noted that different manufacturers have varying levels of faith in their own product, and sometimes this is represented in shorter warranty times.

EXPECTED LIFESPAN

The expected life-span of 40-50 years is the anticipated duration that uPVC windows are designed to endure without significant deterioration. This considers factors such as material strength, resistance to weathering, and overall structural integrity over a prolonged period. It should be noted that this is a subjective topic and the expected lifespan is a design consideration, but not accounted for in the building code.

UV RESISTANCE CERTIFICATE

Licence Certificate



This certificate is granted to

aluplast P/L

who has complied with the requirements for registration as a Licensee of the Industry Code of Practice for uPVC Window & Door Profiles Trade Mark and is hereby entitled to use the Trade Mark in accordance with the Vinyl Council of Australia's Licence Agreement

004
Trade Mark Licence Registration Number

17 August 2023
Registration Date

17 August 2025
Expiry Date



Signature: Chief Executive, Vinyl Council of Australia Dated: 23 /8/2023



ACN 083 012 533 1.02 Junction Business Centre, 22 St Kilda Road St Kilda VIC 3182

SCRATCH RESISTANCE

STÄRKE Ambiance uPVC frames are durable and resilient, however, it is possible to scratch them with a sharp object or similar. The frames are supplied to site with a tape applied for protection. If the frames do become scratched, the uPVC profile is coloured through the entire profile helping small scratches to blend in easily. However for more visible defects there are three alternative methods listed below, in order of difficulty and cost.

REPAIR METHODS

MARKER PEN

This option is the simplest and fastest way to cover small scratches and scuffs on uPVC profiles. It involves using a marker pen specifically designed for touch-ups on uPVC profiles. These contain a special ink, and are available in many different colours.



WAX

Wax is a hard and durable filler. This option is typically used for high use areas and deep scratches. It is melted into place to ensure a secure bond with the uPVC profile, and it is available in a large range of colours. The finish matches the uPVC profile to ensure it blends in with the profile.



RE-FOIL

Re-foiling is the solution if the other options are not suitable. This involves removing the existing foil over the entire length of the affected profile and applying a new foil to cover the profile. It is applied with heat to bond to the uPVC profile and is available in multiple colours and finishes to match the existing profiles.



NZS4211 SUMMARY

Stärke Ambiance 70mm Inline Window System

Product	Test Report Number	Standard Acheived	Water Penetration	ULS	SLS	Air Leakage	Max Sqm (m2)
OI Hinge door 2.1 × 1.1	AS-228A	NZS 4211:2008	455Pa	±4000Pa	±1515Pa	Pass A/C	Test-2.31 +15% - 2.65
OO Hinge door 2.1 × 1.15	AS-227A	NZS 4211:2008	900Pa	±4000Pa	N/R	Pass A/C	Test-2.415 +15% - 2.77
OO French Door 2.1 × 2.23	AS-229A	NZS 4211:2008	600Pa	±4000Pa	±1515Pa	Pass A/C	Test-4.683 +15%-5.39
Fixed Window 2.01 × 2.1	AS-230A	NZS 4211:2008	455Pa	±2500Pa	±1515Pa	Pass A/C	Test-4.22 +15%-4.85
Fixed Window 1.8 × 0.8	SWTL	AS/NZS 4284	1500Pa Cyclic	±7000Pa	±2500Pa	Pass A/C	Test-1.44 +15%-1.656
VarioSlide 2.4 × 2.5	AZT00499 .23	NZS 4211:2008	300Pa	±2000Pa	±1250Pa	Pass A/C	Test-6 +15%-6.9
Tilt & Turn Window 2.1 × 1.2	AS-230A	NZS 4211:2008	455Pa	±2500Pa	±1515Pa	Pass A/C	Test-2.52 +15%-2.9
SmartSlide 2.39 × 2.6	AS-225A	NZS 4211:2008	600Pa	±3000Pa	±1515Pa	Pass A/C	Test-6.214 +15%-7.15

NZS3604 Wind Pressures

	Low	Medium	High	Very High	X High	Xtreme
ULS	720	960	1360	1760	2130	2500
SLS	510	680	970	1250	1515	n/a
Water	153	204	291	375	455	n/a
m/s	32	37	44	50	55	65

ACOUSTIC TEST REPORT

uPVC Acoustic Datasheet

Glazing Spec	RW (C, CTR) Glazing (DB)	RW (C, CTR) Window (DB)	Report Number
4/16/4 T AR thermal spacer + argon)	31(-2,-5)	34(-2,-5)	LA-01228:b/2010
6/16/4 T Ar	34(-1,-5)	38(-2,-6)	
6/16/6 T Ar	35(-3,-7)	37(-2,-4)	
44.2/16/4 T Ar	37(-1,-5)	41(-2,-5)	
44.2/16/6 T Ar	39(-4,-8)	41(-2,-5)	
33.1f.acoustic./16/6 T Ar	40(-2,-6)	43(-2,-6)	
44.2f.acoustic./16/6 T Ar	41(-2,-6)	43(-2,-5)	
8 VSG TF/16/6	42	42(-2,-6)	
9 VSG Si/16/6	41	42(-2,-5)	16129751/Z01 R1
9 VSG Si/16/10	45	44(-1,-2)	16129751/Z03 R1
13 VSG Si/19/9 VSG Si	48	45(-1,-3)	16129751/Z05 R1
4/16/4		33	010424.S24
6/16/4		37	010424.S21
10/16/4		39	001127.P14



BURGLAR INTRUSIONS

Product	Class
Fixed	RC2
Awning/Casement	RC1
Tilt & Turn	RC2
Hinged Door	RC2
Varioslide	RC1
SmartSlide	RC2
LiftSlide	RC2
Invisifold	RC1

RC stands for Resistance Class and is the measure in the European classification system DIN EN 1627 for the performance of windows and doors against forced entry attempts. There are 7 resistance class specifications, ranging up to RC6.

RC1	RC2
Attempted break-in with physical force such as kicking, jumping against, pushing up or similar.	Attempted break-in with simple tools such as screw-drivers, pliers and wedges, pliers and wedges to break open the window
Resistance time required = none	Resistance time required = 3 minutes

AWNING SIZE MATRIX

Matrix	
✓	Possible
✓	Not Recommended
✗	Cannot Do

Notes
Where an asterisk (*) is present, this unit cannot be done in toughened glass.

Double Glazing

Without Restrictors

HEIGHT	WIDTH											
	600	700	800	900	1000	1100	1200	1300	1400	1500	1600	
600	✓	✓	✓	✓	✓	✓	✓	✓	✓	✓	✗	
700	✓	✓	✓	✓	✓	✓	✓	✓	✓	✓	✗	
800	✓	✓	✓	✓	✓	✓	✓	✓	✓	✓	✗	
900	✓	✓	✓	✓	✓	✓	✓	✓	✓	✓	✓	
1000	✓	✓	✓	✓	✓	✓	✓	✓	✓	✓	✓	
1100	✓	✓	✓	✓	✓	✓	✓	✓	✓	✓	✓	
1200	✓	✓	✓	✓	✓	✓	✓	✓	✓	✓	✓	
1300	✓	✓	✓	✓	✓	✓	✓	✓	✓	✓	✓*	
1400	✓	✓	✓	✓	✓	✓	✓	✓	✓	✓*	✓*	
1500	✓	✓	✓	✓	✓	✓	✓	✓	✓*	✗	✗	
1600	✓	✓	✓	✓	✓	✓	✓	✓*	✓*	✗	✗	

With Restrictors

HEIGHT	WIDTH											
	600	700	800	900	1000	1100	1200	1300	1400	1500	1600	
600	✓	✓	✓	✓	✓	✓	✓	✓	✓	✓	✗	
700	✓	✓	✓	✓	✓	✓	✓	✓	✗	✗	✗	
800	✓	✓	✓	✓	✓	✓	✓	✗	✗	✗	✗	
900	✓	✓	✓	✓	✓	✗	✗	✗	✗	✗	✗	
1000	✓	✓	✓	✓	✓	✓	✗	✗	✗	✗	✗	
1100	✓	✓	✓	✓	✓	✓*	✗	✗	✗	✗	✗	
1200	✓	✓	✓	✓	✓	✓	✓	✓	✓	✓	✗	
1300	✓	✓	✓	✓	✓	✓	✓	✓	✓	✓	✓*	
1400	✓	✓	✓	✓	✓	✓	✓	✓	✓	✓*	✓*	
1500	✓	✓	✓	✓	✓	✓	✓	✓	✓*	✗	✗	
1600	✓	✓	✓	✓	✓	✓	✓	✓*	✓*	✗	✗	



AWNING SIZE MATRIX

Matrix	
✓	Possible
✓	Not Recommended
✗	Cannot Do

Notes
Where an asterisk (*) is present, this unit cannot be done in toughened glass.

Triple Glazing

Without Restrictors

HEIGHT	WIDTH											
	600	700	800	900	1000	1100	1200	1300	1400	1500	1600	
600	✓	✓	✓	✓	✓	✓	✓	✓	✗	✗	✗	
700	✓	✓	✓	✓	✓	✓	✓	✓	✗	✗	✗	
800	✓	✓	✓	✓	✓	✓	✓	✓	✓	✓	✗	
900	✓	✓	✓	✓	✓	✓	✓	✓	✓	✓	✓	
1000	✓	✓	✓	✓	✓	✓	✓	✓	✓	✓	✓	
1100	✓	✓	✓	✓	✓	✓	✓	✓	✓	✓	✓	
1200	✓	✓	✓	✓	✓	✓	✓	✓*	✓*	✗	✗	
1300	✓	✓	✓	✓	✓	✓	✓*	✓*	✗	✗	✗	
1400	✓	✓	✓	✓	✓	✓*	✓*	✗	✗	✗	✗	
1500	✓	✓	✓	✓	✓*	✓*	✗	✗	✗	✗	✗	
1600	✓	✓	✓	✓	✓*	✗	✗	✗	✗	✗	✗	

With Restrictors

HEIGHT	WIDTH											
	600	700	800	900	1000	1100	1200	1300	1400	1500	1600	
600	✓	✓	✓	✓	✓	✓	✓	✗	✗	✗	✗	
700	✓	✓	✓	✓	✗	✗	✗	✗	✗	✗	✗	
800	✓	✓	✓	✓	✗	✗	✗	✗	✗	✗	✗	
900	✓	✓	✓	✗	✗	✗	✗	✗	✗	✗	✗	
1000	✓	✓	✓	✓	✗	✗	✗	✗	✗	✗	✗	
1100	✓	✓	✓	✗	✗	✗	✗	✗	✗	✗	✗	
1200	✓	✓	✓	✓	✓	✓	✓	✓*	✓*	✗	✗	
1300	✓	✓	✓	✓	✓	✓	✓*	✓*	✗	✗	✗	
1400	✓	✓	✓	✓	✓	✓*	✓*	✗	✗	✗	✗	
1500	✓	✓	✓	✓	✓*	✓*	✗	✗	✗	✗	✗	
1600	✓	✓	✓	✓	✓*	✗	✗	✗	✗	✗	✗	

RECYCLED CONTENT

Parts of the following document have been translated into English

Gütegemeinschaft Kunststoff-Fensterprofilsysteme e.V.



Gütegemeinschaft Kunststoff-Fensterprofilsysteme e.V. | Am Hofgarten 1-2 | 53113 Bonn

aluplast GmbH
Herr Arno Bender
Auf der Breit 2
76227 Karlsruhe

Am Hofgarten 1-2 | 53113 Bonn
 Telefon +49 (0) 228 766 76 54
 Telefax +49 (0) 228 766 76 50

Deutsche Bank AG, Bonn
 IBAN DE71 3807 0059 0028 5296 00
 BIC DEUTDE33HAN

Commerzbank AG, Bonn
 IBAN DE42 3804 0007 0101 8787 00
 BIC COBADE33HAN

Sitz: Bonn
 Amtsgericht: Bonn
 VR 9064
 USt-IdNr. DE815130783
 St.-Nr. 205/5774/032

July 5, 2022

Confirmation of the recycled content of window profiles of the aluplast IDEAL 7000 system

Dear Mr. Bender

Your company aluplast applied to our quality association for confirmation of the recyclable content of the following profiles of the IDEAL 7000 system. For this purpose, we received the dimensioned cross-sectional drawings of these profiles from you, on which the mass proportions of virgin material and recyclable material (rPVC) are specified. These mass proportions result from the design of the extrusion tool and are therefore tool-related. Fluctuations are only possible to a small extent. The following recyclable proportions result from the documents mentioned:

Profile number Article number	Designation	Mass of fresh material (g/m)	Mass rPVC (g/m)	Mass fraction rPVC (%)
170 002/302/402 0000013 170 002 0000013	Frame	538	919	63,1
170 020/320/420 0000013 170 020 0000013	Sash	701	822	54,0
TOTAL Window	Frame + Sash	1239	1741	58,4

Summary:

- A window consisting of the above-mentioned profiles from the aluplast IDEAL 7000 system has a mass proportion of recycled material of >55%.
- According to the statement of our quality association dated August 6, 2019 on the use of recycled materials in window profiles, retention samples with recognizable profile markings should be kept when producing windows for specially funded building projects. This means that, upon request (e.g. from the funding body), an analysis of the recycled content of the profiles used for a project can be carried out subsequently.

Best regards
 Quality Association for Plastic Window Profile Systems
 e.V. I.A. Bernhard Elias

aluplast IDEAL 7000 2512 17 04 2022

info@gkfp.de
 www.gkfp.de





PRODUCT TECHNICAL STATEMENT

KEY INFORMATION

1.0

Summary of Description of Building Product

Stärke Ambiance Inline Window system uPVC windows and doors are a standard New Zealand residential joinery range which can be double or triple glazed. They include:

- ▶ Fixed, Awning and Casement Open Out Windows
- ▶ Tilt & Turn Open-In Windows
- ▶ VarioSlide Sliding & Stacking Doors
- ▶ Smartslide Sliding Doors
- ▶ Liftslide Sliding Doors
- ▶ Inward and outward opening French Doors

Continuation of intended use can be found in item 9. Supporting information about Intended use of Building Product or Method.

Matters that should be taken into account in the use or application of the building product can be found in 6. Conditions and Limitations of Use.

2.0

Summary of Intended Use of Building Product

Stärke Ambiance Inline Window system uPVC windows and doors are for use as part of the building envelope in residential buildings. They contribute to natural daylight and ventilation and are suitable for use in building envelopes enclosing spaces where the temperature and/or humidity are modified.

Continuation of intended use can be found in item 8. Supporting information about intended use of Building Product.

3.0

Building Code Provisions

The clauses of the New Zealand Building Code that are relevant to the intended use and with which the building product complies or contributes to (where used as part of a system)

- ▶ **B1 Structure:** B1.3.1; B1.3.2; B1.3.3 (a, b, h); B1.3.4
- ▶ **B2 Durability:** B2.3.1(b); B2.3.1(c) (For Hardware)
- ▶ **E2 External Moisture:** E2.3.2; E2.3.7
- ▶ **E3 Internal Moisture:** E3.3.1 (contributes to)
- ▶ **F2 Hazardous Building Materials:** F2.3.1, F2.3.3
- ▶ **F4 Safety from Falling:** F4.3.1
- ▶ **G4 Ventilation:** G4.3.1; G4.3.3 (contributes to)
- ▶ **G7 Natural light:** G7.3.1 (contributes to); G7.3.2 (contributes to)
- ▶ **H1 Energy Efficiency:** H1.3.1; H1.3.2E (contributes to)

If designed, used installed & maintained in accordance with the scope of this Technical Statement, the above-mentioned product will meet the above-mentioned provisions of the NZBC. How the building method or product complies or contributes can be found in item 12. Basis for Certification. Any qualification on the extent of that compliance can be found in item 6. Conditions and limitations of use.



4.0

Conditions and Limitations of Use

Stärke Ambiance Inline Window system Suite uPVC Windows and Doors must be installed in accordance with the WANZ guide to Window Installation, and NZBC E2/AS1 or as according to Stärke specific installation detailing.

Product must be maintained in accordance with the Stärke Maintenance and Care Guide.

All products detailed below are suitable for use in the EXTRA HIGH wind zones (as defined in NZS3604)

- ▶ Stärke Ambiance Inline Window system Fixed window up to 2100mm high x 3210mm wide
- ▶ Stärke Ambiance Inline Window system Fixed window up to 1400mm high x 1600mm wide
- ▶ Stärke Ambiance Inline Window system Hinged Door open out up to 2100mm high x 1150mm wide
- ▶ Stärke Ambiance Inline Window system Hinged Door open in up to 2100mm high x 1400mm wide
- ▶ Stärke Ambiance Inline Window system Hinged French Door open out up to 2100mm high x 2230mm wide
- ▶ Smartslide Sliding Doors up to 2.64m high x 5.8m wide
- ▶ Liftslide Sliding Doors up to 2.64m high x 8m wide

All products detailed below are suitable for use in the VERY HIGH wind zones (as defined in NZS3604)

- ▶ VarioSlide Sliding & Stacking Doors up to 2400mm high x 5800mm wide

The following attributes shall be determined specifically:

- ▶ Vision barriers must be specified when required for compliance with NZBC F2.3.2
- ▶ Safety glazing must be specified when required for compliance with NZBC F2.3.3
- ▶ Suitable restrictor stays must be specified when required for compliance with NZBC F4.3.1

NOTE: Together, items 3,4,5 and 6 define the scope of use.

5.0

Health and Safety Information

The compliance with any manufacturer's installation instructions, OH&S statements, MSDS's and other Health and Safety declarations will provide the necessary Health and Safety Information pertaining to the product.

6.0

Signatures

Name and signature of the Product Technical Statement issuer's authorised representative



Ken Pridham
Commercial Director

For and on behalf of Stärke Group Limited

7.0

Supporting Information About Description

The following models of windows and doors are covered by this certificate:

- ▶ Stärke Ambiance Inline Window system Fixed window up to 2100mm high x 3210mm wide
- ▶ Stärke Ambiance Inline Window system Awning window up to 1400mm high x 1600mm wide
- ▶ Stärke Ambiance Inline Window system Hinged Door open out up to 2100mm high x 1150mm wide
- ▶ Stärke Ambiance Inline Window system Hinged Door open in up to 2100mm high x 1400mm wide
- ▶ Stärke Ambiance Inline Window system Hinged French Door open out up to 2100mm high x 2230mm wide
- ▶ VarioSlide Sliding & Stacking Doors up to 2400mm high x 7000mm wide
- ▶ Smartslide Sliding Doors up to 2.64m high x 5.8m wide
- ▶ Liftslide Sliding Doors up to 2.64m high x 8m wide

8.0

Supporting Information About Intended Use

Stärke Ambiance Inline Window system Suite Windows and Door assemblies are for use in private houses, office blocks, and public and commercial buildings. Product must be installed as per NZBC E2/AS1, or Stärke specific installation details and maintained in accordance with the Stärke Maintenance and Care Guide.

9.0

Supporting Information About Conditions and Limitations of Use

Stärke Ambiance Inline Window system Window and Door assemblies must be fabricated by Stärke Group Limited, 4 Wilco Place Wiri (www.starke.co.nz).

All conditions and limitations of use are stated above in item 6. Conditions and Limitations of use.

10.0

Basis for Compliance

- ▶ **B1 Structure:** by testing and compliance with verification method B1/VM1 and referenced standard NZS4211: 2008
- ▶ **B2 Durability:** By analysis and comparison with Verification Method B2/VM1
- ▶ **E2 External Moisture:** By testing and comparison with Acceptable Solution E2/AS1 and referenced standard NZS4211: 2008
- ▶ **E3 Internal Moisture:** By analysis and comparison with Acceptable Solutions E3/AS1, G4/AS1 and H1/AS1
- ▶ **F2 Hazardous Building Materials:** By comparison with the provisions of Acceptable Solution F2/AS1
- ▶ **F4 Safety From Falling:** By comparison with the provisions of Acceptable Solution F4/AS1
- ▶ **G4 Ventilation:** By comparison with the provisions of Acceptable Solution G4/AS1
- ▶ **G7 Natural Light:** By comparison with the provisions of Acceptable Solution G7/AS1
- ▶ **H1 Energy Efficiency:** By comparison with the provisions of Acceptable Solution H1/AS1



11.0

Supporting Documentation

- ▶ New Zealand Standard 4211: 2008 Specification and performance of Windows
- ▶ Australian Standard 2047: 2014 Windows and External Glazed Doors
- ▶ WGANZ Guide to window installation Version 1.5 1 August 2019
- ▶ Acceptable Solutions and Verification Methods for New Zealand Building Code:
 - ▶ Clause B1 Structure 1st Edition (Amendment 19) 28 November 2019 (B1/VM1)
 - ▶ Clause B2 Durability 2nd Edition (Amendment 12) 28 November 2019 (B2/VM1)
 - ▶ Clause E2 External Moisture 3rd Edition (Amendment 10) 5 November 2020 (E2/AS1)
 - ▶ Clause E3 Internal Moisture 2nd Edition (Amendment 6) 1 Jan 2017 (E3/AS1)
 - ▶ Clause F2 Hazardous Building Materials 1st Edition (amendment 3) 1 Jan 2017 (F2/AS1)
 - ▶ Clause F4 Safety from Falling 3rd Edition (amendment 2) 1 Jan 2017 (F4/AS1)
 - ▶ Clause G4 Ventilation 4th Edition 27 June 2019 (G4/AS1)
 - ▶ Clause G7 Natural Light 1st Edition (Amendment 2) 14 February 2014 (G7/AS1)
 - ▶ Clause H1 Energy Efficiency 4th Edition (Amendment 4) 28 November 2019
- ▶ Highbrook Windows testing Laboratory REPORT NO. AS-228A Open In Hinge Door to NZ4211 (available from Stärke)
- ▶ Highbrook Windows testing Laboratory REPORT NO. AS-227A Open Out Hinge Door to NZ4211 (available from Stärke)
- ▶ Highbrook Windows testing Laboratory REPORT NO. AS-229A Open Out French Door to NZ4211 (available from Stärke)
- ▶ Highbrook Windows testing Laboratory REPORT NO. AS-230A Awning and Fixed Window to NZ4211 (available from Stärke)
- ▶ Stärke Maintenance and Care Guide Jan 2019

12.0

Conditions Relating to Specification

This Product Technical Specification can only be reproduced in full and is a controlled document. Current as:

- ▶ Version 1.1, 18 January 2022

Latest versions of Product Technical Specifications can be obtained by contacting Stärke Group Ltd directly as per contact details.

13.0

Warranty

Stärke Ambiance Inline Window system Suite Windows & doors have a 10-year manufacturer's warranty. For more details, please contact Stärke for a copy of our Terms and Conditions.

APPENDIX

ENGINEERING JUDGEMENT

This engineering judgement undertaken by Oculus Engineering of the STÄRKE Ambiance uPVC Inline Window System includes testing, performance and compliance of our recessed uPVC system.

Scan the QR code to download the engineering judgement

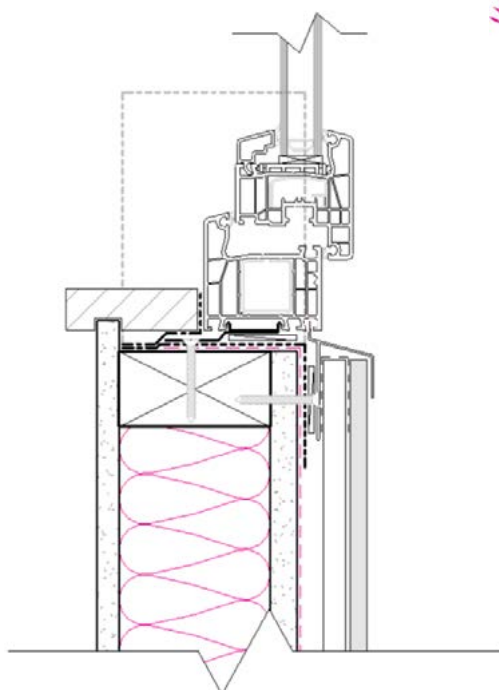

STARKE Ambiance Inline Window System

Engineering Judgement

Author: Erik Todorov

27/09/22

Job: J-00025

AMBIANCE UPVC SUSTAINABLE ENGINEERING REPORT

14 November 2022

Starke Ambiance SELtd Accepted Joinery

Twenty-one frame profiles of Starke Ambiance frames have been modelled by Starke to determine Uf value and fRsi of the frames. Sustainable Engineering has reviewed these reports and collated the data for use in PHPP.

Boundary conditions are set per ISO 10077-2 in Flixo Frame software.

Table 1: PHPP Data

Window frames									
ID	Description	U _f -Value				Frame width			
		left	right	bottom	above	left	right	bottom	above
		Wl(m ² K)	Wr(m ² K)	Wb(m ² K)	Wa(m ² K)	m	m	m	m
01ud	Starke Ambiance Fixed White	1.30	1.30	1.30	1.30	0.070	0.070	0.070	0.070
02ud	Starke Ambiance Awning White	1.34	1.34	1.34	1.34	0.117	0.117	0.117	0.117
03ud	Starke Ambiance Tilt & Turn White	1.38	1.38	1.38	1.38	0.119	0.119	0.119	0.119
04ud	Starke Ambiance Hinge Door White	1.43	1.43	1.43	1.43	0.147	0.147	0.147	0.147
05ud	Starke Ambiance Sliding Door Fixed	1.37	1.62	1.34	1.34	0.056	0.055	0.056	0.056
06ud	Starke Ambiance Sliding Door Operable	1.62	1.52	1.52	1.56	0.055	0.145	0.145	0.145
07ud	Starke Ambiance Fixed Black	1.34	1.34	1.34	1.34	0.070	0.070	0.070	0.070
08ud	Starke Ambiance Awning Black	1.36	1.36	1.36	1.36	0.117	0.117	0.117	0.117
09ud	Starke Ambiance Tilt & Turn Black	1.47	1.47	1.47	1.47	0.119	0.119	0.119	0.119
10ud	Starke Ambiance Hinge Door Black	1.44	1.44	1.44	1.44	0.147	0.147	0.147	0.147

Note that the Sliding door operable head and jamb fails the PHPP9 fRSI criteria in warm and warm-temperate climates. We recommend discussing with your certifier and using the PHPP10 criteria.

Both Black and White options meet the fRSI criteria for PHPP9 in warm and warm-temperate climates.



Table 2: White

Window Frame	Uf [W/(m ² K)]	Frame height (m)	fRsi
Fixed	1.30	0.070	0.73
Awning	1.34	0.117	0.68
Hinge Door	1.43	0.147	0.74
Tilt and Turn	1.38	0.119	0.66
Mullion Double Tilt Turn	1.07	0.166	0.65
Mullion Fixed	1.39	0.084	0.74
Mullion One Tilt and Turn Sash	1.48	0.125	0.67

Table 3: Black

Window Frame	Uf [W/(m ² K)]	Frame height (m)	fRsi
Fixed	1.34	0.070	0.73
Awning	1.36	0.117	0.68
Hinge Door	1.44	0.147	0.65
Tilt and Turn	1.47	0.119	0.65
Mullion Double Tilt Turn	1.07	0.166	0.65
Mullion Fixed	1.39	0.084	0.74
Mullion One Tilt and Turn Sash	1.48	0.125	0.67

Table 4: Sliding

Window Frame	Uf [W/(m ² K)]	Frame height (m)	fRsi
Fixed Head	1.34	0.056	0.72
Fixed Jamb	1.37	0.056	0.72
Fixed Sill	1.34	0.056	0.72
Mullion	1.62	0.109	0.67
Sliding Head	1.56	0.145	0.53
Sliding Jamb	1.52	0.145	0.54
Sliding Sill	1.52	0.145	0.55

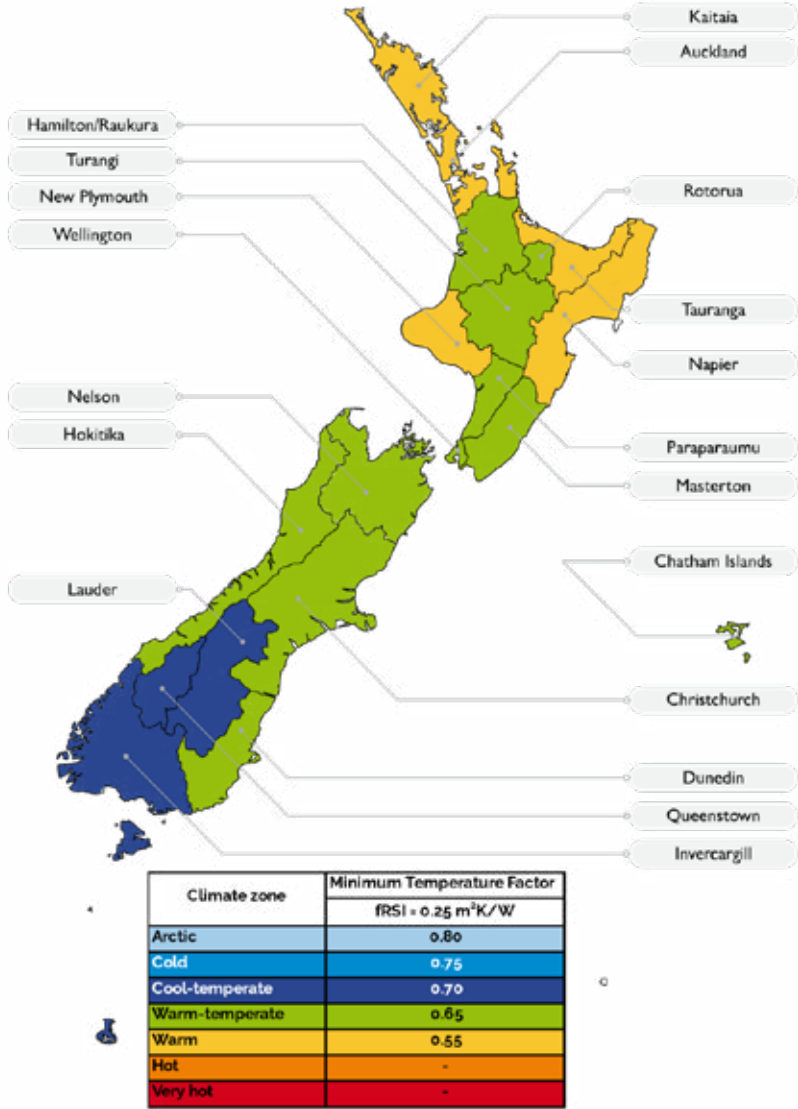

Figure 1: This map shows the three different fRSI zones at the weather station altitudes. The climate zone and thus the fRSI requirements also vary with altitude as the average temperatures typically drop by 0.6C per 100m of elevation gain. In general these zones can be used without considering the elevation change. Illustration: Sustainable Engineering Ltd. fRSI requirements from [PHI Passive House Standard Building Criteria](#).



THERMAL CALCULATIONS



4 May 2022

Project Reference Starke Windows J-00025

Benjy Simmons
Starke Windows

Email: benjy@starke.co.nz

Dear Benjy,

Please find the results of our isothermal detail review as per table below.



1. BACKGROUND

Oculus reviewed the frame installation as follows:

	U_f	U_{wall}	$\psi_{Installation}$	fRS_i installation
Starke 70 – wd frame, gyp, recessed win sill, gen clad	1.39 W/m ² K	0.327 W/m ² K	0.082 W/mK	0.653
Starke 125 - wd frame, gyp, recessed slider sill, gen clad	2.26 W/m ² K	0.223 W/m ² K	0.081 W/mK	0.484
Starke 140 - wd frame, gyp, recessed dr sill, gen clad	1.23 W/m ² K	0.223 W/m ² K	0.051	0.610

Kind Regards,

Denise Martin



THERMAL CALCULATIONS



Oculus Architectural Engineering Ltd
Denise Martin

Starke 70 fRSi

$\theta_{si\ min} = 13.07\ ^\circ C$
 $f_{Rsi} = 0.653$
 $\varphi_{s(50\%)} = 78\%$

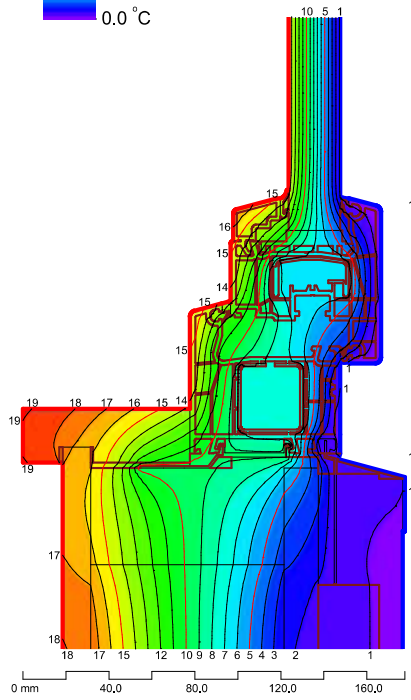
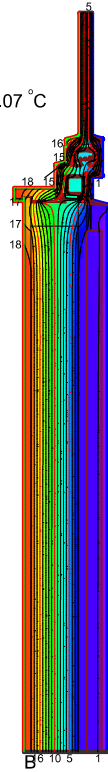
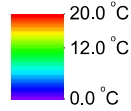

Boundary Condition	q[W/m ²]	θ[°C]	R[(m ² ·K)/W]	ε
Epsilon 0.9				0.900
Psi-Aussen, Wand (1)		0.000	0.040	
Symmetry/Model section	0.000			
fRSi-Innen-Wand, Decke, Boden		20.000	0.250	

Material	λ[W/(m·K)]	ε
Aluminium (Si Alloys)	160.000	0.900
EPDM (ethylene propylene diene monomer)	0.250	0.900
Elastomeric foam, flexible	0.050	0.900
Gypsum plasterboard	0.250	0.900
Mineralwolle Nennwert L=0,035	0.035	0.900
PVC (polyvinylchloride), rigid	0.170	0.900
Panel	0.035	0.900
Silicone, filled	0.500	0.900
Slightly ventilated air cavity *		
Steel	50.000	0.900
Timber 450 kg/m3 (softwoods)	0.120	0.900
Unventilated air cavity *		

* EN ISO 10077-2:2017, 6.4.3/anisotrop

5/4/2022
\\Mac\Home\Desktop\Starke Windows.flx

9

flxo pro 8.1.1005.1



THERMAL CALCULATIONS



Oculus Architectural Engineering Ltd
Denise Martin
Starke 70 - Recessed Sill

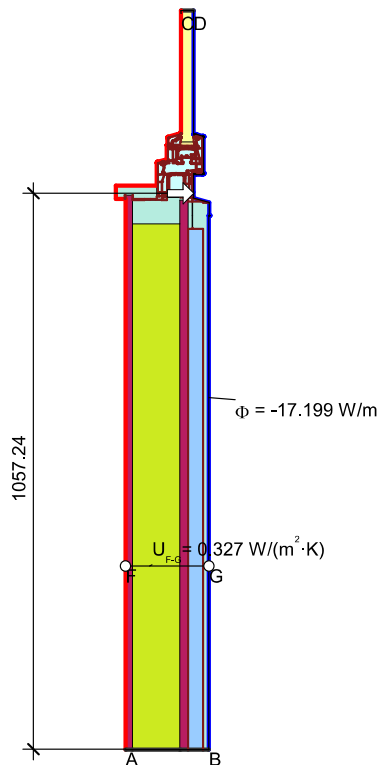

Starke 70

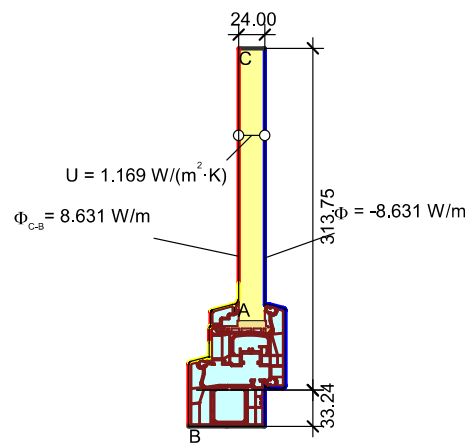

$$U_f = \frac{\frac{8.631}{20.0} - 1.169 \cdot 0.314}{0.033} = 1.95 \text{ W/(m}^2\text{·K)}$$

$$\psi_{A-E-C} = \frac{17.188}{20.0} - 0.327 \cdot 1.057 - \frac{8.631}{20.0} = 0.082 \text{ W/(m·K)}$$

Boundary Condition	q[W/m ²]	θ[°C]	R[(m ² ·K)/W]	ε
Epsilon 0.9				0.900
Psi-Aussen, Wand (1)	0,000		0,040	
Psi-Innen-Wärmestrom horizontal	20,000		0,130	
Symmetry/Model section	0,000			

Material	λ[W/(m·K)]	ε
Aluminium (Si Alloys)	160,000	0,900
EPDM (ethylene propylene diene monomer)	0,250	0,900
Elastomeric foam, flexible	0,050	0,900
Gypsum plasterboard	0,250	0,900
Mineralwolle Nennwert L=0,035	0,035	0,900
PVC (polyvinylchloride), rigid	0,170	0,900
Panel	0,035	0,900
Silicone, filled	0,500	0,900
Slightly ventilated air cavity *		
Steel	50,000	0,900
Timber 450 kg/m3 (softwoods)	0,120	0,900
Unventilated air cavity *		
* EN ISO 10077-2:2017, 6.4.3/anisotrop		

Boundary Condition	q[W/m ²]	θ[°C]	R[(m ² ·K)/W]	ε
Epsilon 0.9				0.900
Exterior, frame	0,000		0,040	
Interior, frame, normal	20,000		0,130	
Interior, frame, reduced	20,000		0,200	
Symmetry/Model section	0,000			

5/4/2022
\\Mac\Home\Desktop\Starke Windows.flx

4

flxo pro 8.1.1005.1

THERMAL CALCULATIONS

Oculus Architectural Engineering Ltd
Denise Martin

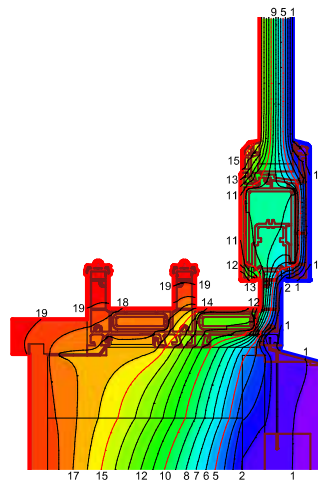
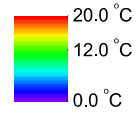
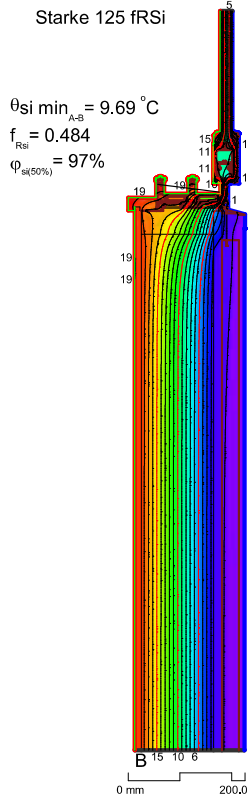

Boundary Condition	$q[W/m^2]$	$\theta[^\circ C]$	$R[(m^2 \cdot K)/W]$	ϵ
Epsilon 0.9				0.900
PSi-Aussen, Wand (1)		0,000	0,040	
Symmetry/Model section	0,000			
fRSi-Innen-Wand, Decke, Boden		20,000	0,250	

Material	$\lambda[W/(m \cdot K)]$	ϵ
Aluminium (Si Alloys)	160,000	0,900
EPDM (ethylene propylene diene monomer)	0,250	0,900
Elastomeric foam, flexible	0,050	0,900
Gypsum plasterboard	0,250	0,900
Mineraltwolle Nennwert L=0,035	0,035	0,900
PVC (polyvinylchloride), rigid	0,170	0,900
Panel	0,035	0,900
Pile weather stripping (polyester mohair)	0,140	0,900
Silicone, filled	0,500	0,900
Slightly ventilated air cavity *		
Steel	50,000	0,900
Timber 450 kg/m3 (softwoods)	0,120	0,900
Unventilated air cavity *		
* EN ISO 10077-2:2017, 6.4.3/anisotrop		

5/4/2022
\\Mac\Home\Desktop\Starke Windows.flx

9

flxo pro 8.1.1005.1



THERMAL CALCULATIONS



Oculus Architectural Engineering Ltd
Denise Martin

Starke 125 - Recessed Sill

Starke 125

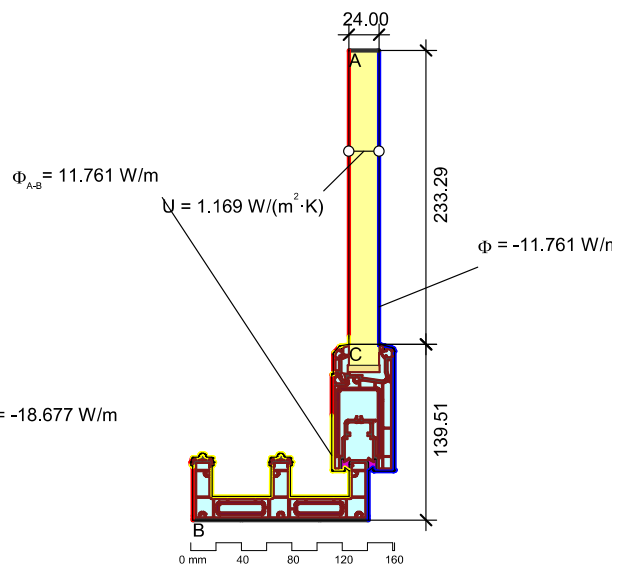
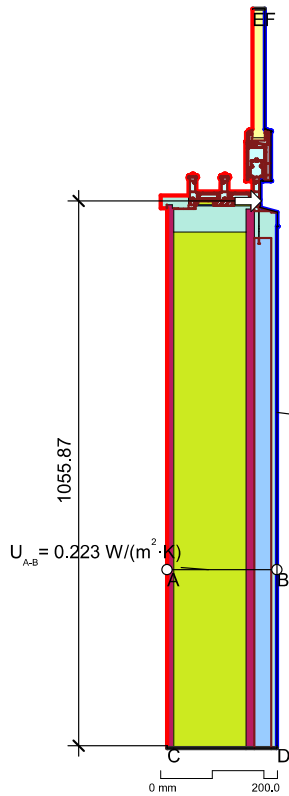

$$U_{f.c.B} = \frac{\frac{11.761}{20.0} - 1.169 \cdot 0.233}{0.14} = 2.26 \text{ W/(m}^2 \cdot \text{K)}$$

$$\psi_{c-g-e} = \frac{18.638}{20.0} - 0.223 \cdot 1.056 - \frac{12.319}{20.0} = 0.081 \text{ W/(m}^2 \cdot \text{K)}$$

Boundary Condition	q[W/m ²]	θ[°C]	R[(m ² ·K)/W]	ε
Epsilon 0,9				0,900
Psi-Aussen, Wand (1)	0,000		0,040	
Psi-Innen-Wärmestrom horizontal	20,000		0,130	
Symmetry/Model section	0,000			

Material	λ[W/(m·K)]	ε
Aluminium (Si Alloys)	160,000	0,900
EPDM (ethylene propylene diene monomer)	0,250	0,900
Elastomeric foam, flexible	0,050	0,900
Gypsum plasterboard	0,250	0,900
Mineralwolle Nennwert L=0,035	0,035	0,900
PVC (polyvinylchloride), rigid	0,170	0,900
Panel	0,035	0,900
Pile weather stripping (polyester mohair)	0,140	0,900
Silicone, filled	0,500	0,900
Slightly ventilated air cavity *		
Steel	50,000	0,900
Timber 450 kg/m ³ (softwoods)	0,120	0,900
Unventilated air cavity *		
* EN ISO 10077-2:2017, 6.4.3/anisotrop		

Boundary Condition	q[W/m ²]	θ[°C]	R[(m ² ·K)/W]	ε
Epsilon 0,9				0,900
Interior, frame, normal	20,000		0,130	
Interior, frame, reduced	20,000		0,200	
Psi-Aussen, Wand (1)	0,000		0,040	
Symmetry/Model section	0,000			

5/4/2022
\\Mac\Home\Desktop\Starke Windows.flx

6

flxo pro 8.1.1005.1

THERMAL CALCULATIONS



Oculus Architectural Engineering Ltd
Denise Martin

Starke 140 fRSi

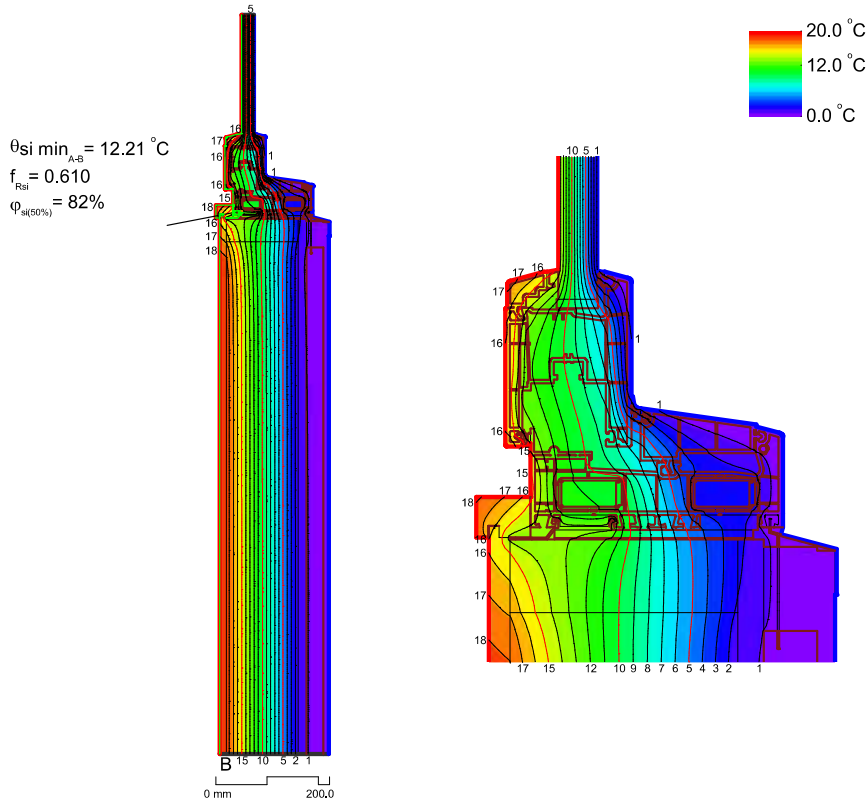

Boundary Condition	q[W/m ²]	θ[°C]	R[(m ² ·K)/W]	ε
Epsilon 0.9				0.900
Psi-Aussen, Wand (1)		0.000	0.040	
Symmetry/Model section	0.000			
fRSi-Innen-Wand, Decke, Boden		20.000	0.250	

Material	λ[W/(m·K)]	ε
Aluminium (Si Alloys)	160.000	0.900
EPDM (ethylene propylene diene monomer)	0.250	0.900
Elastomeric foam, flexible	0.050	0.900
Gypsum plasterboard	0.250	0.900
Mineralfolle Nennwert L=0,035	0.035	0.900
PVC (polyvinylchloride), rigid	0.170	0.900
Panel	0.035	0.900
Pile weather stripping (polyester mohair)	0.140	0.900
Silicone, filled	0.500	0.900
Slightly ventilated air cavity *		
Steel	50.000	0.900
Timber 450 kg/m ³ (softwoods)	0.120	0.900
Unventilated air cavity *		
* EN ISO 10077-2:2017, 6.4.3/anisotrop		

5/4/2022
\\Mac\Home\Desktop\Starke Windows.flx

8

flxo pro 8.1.1005.1



THERMAL CALCULATIONS

Starke 140



Oculus Architectural Engineering Ltd
Denise Martin

Starke 140 - Recessed Sill

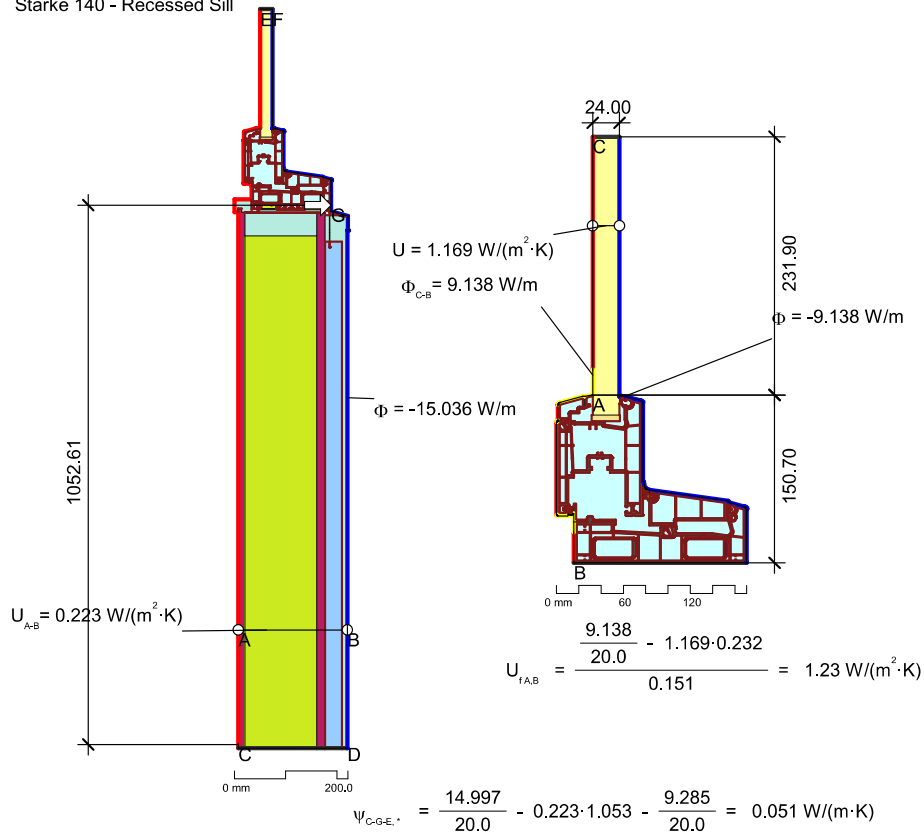

Boundary Condition	q[W/m ²]	θ[C]	R[(m ² ·K)/W]	ε
Epsilon 0.9				0.900
Psi-Aussen, Wand (1)	0.000		0.040	
Psi-Innen-Wärmestrom horizontal	20.000		0.130	
Symmetry/Model section	0.000			

Material	λ[W/(m·K)]	ε
Aluminium (Si Alloys)	160.000	0.900
EPDM (ethylene propylene diene monomer)	0.250	0.900
Elastomeric foam, flexible	0.050	0.900
Gypsum plasterboard	0.250	0.900
Mineralfolle Nennwert L=0,035	0.035	0.900
PVC (polyvinylchloride), rigid	0.170	0.900
Panel	0.035	0.900
Pile weather stripping (polyester mohair)	0.140	0.900
Silicone, filled	0.500	0.900
Slightly ventilated air cavity *		
Steel	50.000	0.900
Timber 450 kg/m ³ (softwoods)	0.120	0.900
Unventilated air cavity *		

* EN ISO 10077-2:2017, 6.4.3/anisotrop

Boundary Condition	q[W/m ²]	θ[C]	R[(m ² ·K)/W]	ε
Epsilon 0.9				0.900
Interior, frame, normal	20.000		0.130	
Interior, frame, reduced	20.000		0.200	
Psi-Aussen, Wand (1)	0.000		0.040	
Symmetry/Model section	0.000			

5/4/2022
\\Mac\Home\Desktop\Starke Windows.flx

7

flxo pro 8.1.1005.1

THERMAL PERFORMANCE GLASS SPACER

CERTIFICATE

Certified Passive House Component

Component-ID 1547sp03 valid until 31st December 2022

Passive House Institute
Dr. Wolfgang Feist
64283 Darmstadt
Germany

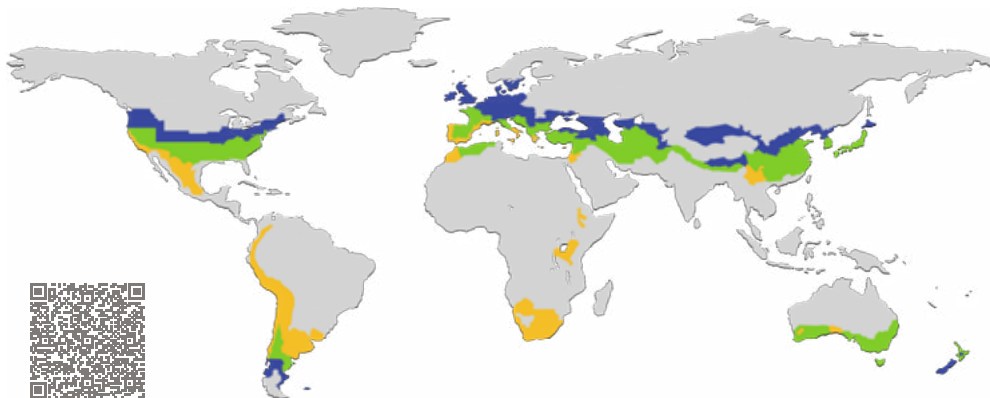

Category: **Spacer for low-E-glazing**
 Manufacturer: **Technoform Glass Insulation GmbH, Lohfelden, Germany**
 Product name: **Technoform-Spacer SP12, SP13, SP14**

This certificate was awarded based on the following criteria:

Depending on the climatic region, the spacer prevents high surface temperatures, which can cause mould. At least 3 out of the 7 reference frames fulfilled the spacer hygiene criteria for the relevant climatic region.

Hygiene $f_{Rsi} \geq 0.70$

The specific resistance of the spacer's edges is greater than the climate-independent minimum requirement.

Efficiency $R_E = 3.40 \text{ m K/W} \geq 1.50 \text{ m K/W}$

Type
Plastic with stainless steel foil
Height Box 2
6.90 mm
Thermal conductivity Box 2
0.310 W/(m K)



cool, temperate climate



CERTIFIED COMPONENT

Passive House Institute

Passive House efficiency class

phE

phD

phC

phB

phA

phA+

www.passivehouse.com

GLASS SPACER

Technoform Glass Insulation GmbH

Matthäus-Merian-Straße 6, 34253 Lohfelden, Germany

☎ | ✉ | 🌐 <http://www.technoform.com> |

Description

The SP12, SP13, SP14 is a polymeric/metal hybride spacer for rigid and tight thermally improved edgebonds of insulating glazing.

Spacer height: 6.90 mm
Thermal conductivity: 0.310 W/(m K) (WA 17/1, ift Rosenheim)
Available spacer widths: 8, 10, 12, 14, 15, 16, 18, 20, 22 and 24 mm

Appropriate secondary seal	Specific edge resistance R_E	Efficiency class
Polysulfide	3.40 m K/W	phB
Polyurethane	3.40 m K/W	phB
Silicone	3.60 m K/W	phB

Explanation

Spacers are categorized into different efficiency classes based on the resistance of their edges R_E . A secondary polysulfide sealant is typically used, unless the spacer is not approved for polysulfide. A detailed report with the calculations is available from either the manufacturer or the Passive House Institute.



































The Passive House Institute has defined global component requirements for seven climate regions. In principle, components that have been certified for climates with higher requirements can also be used in climates with lower requirements. This may be economically advantageous.

Use in PHPP:

If individually calculated values are not available then the thermal bridge loss coefficient specified in this document can be used. In this case, the appropriate reference frame must be selected and a 10% safety margin should be applied.

Further information regarding certification is available on www.passivehouse.com and www.passipedia.org.

GLASS SPACER

Reference frames calculated with Polysulfide					
Climate	Arctic	Cool	Cool temperate ✓	Warm temperate ✓	Warm ✓
Glass	Quadruple	Triple	Triple	Triple	Double
Glass package	4/12/3/12/3/12/4	6/18/2/18/6	6/16/6/16/6	6/16/6/16/6	6/16/6
Glass U-value	0.35 W/(m ² K)	0.52 W/(m ² K)	0.70 W/(m ² K)	0.70 W/(m ² K)	1.20 W/(m ² K)
Timber-aluminium integral frame					
U_f [W/(m ² K)]	0.48	0.62	0.73	0.87	1.03
Ψ_g [W/(m K)]	0.038	0.040	0.040	0.038	0.043
f_{Rsi} [-]	0.77	0.73	0.70 ✓	0.68 ✓	0.58 ✓
Timber-aluminium					
U_f [W/(m ² K)]	0.54	0.57	0.75	0.97	1.19
Ψ_g [W/(m K)]	0.041	0.043	0.042	0.041	0.048
f_{Rsi} [-]	0.73	0.71	0.67	0.64	0.52
Timber					
U_f [W/(m ² K)]	0.51	0.53	0.78	0.86	0.99
Ψ_g [W/(m K)]	0.035	0.039	0.039	0.039	0.043
f_{Rsi} [-]	0.75	0.74	0.71 ✓	0.71 ✓	0.60 ✓
Vinyl					
U_f [W/(m ² K)]	0.70	0.75	0.82	1.02	1.16
Ψ_g [W/(m K)]	0.041	0.044	0.044	0.045	0.050
f_{Rsi} [-]	0.76	0.73	0.71 ✓	0.70 ✓	0.59 ✓
Aluminium					
U_f [W/(m ² K)]	0.60	0.61	0.71	0.73	1.17
Ψ_g [W/(m K)]	0.043	0.048	0.049	0.049	0.055
f_{Rsi} [-]	0.77	0.76 ✓	0.74 ✓	0.74 ✓	0.61 ✓
Curtain wall timber					
U_f [W/(m ² K)]	0.60	0.65	0.66	0.71	1.11
Ψ_g [W/(m K)]	0.056	0.065	0.057	0.057	0.069
f_{Rsi} [-]	0.71	0.70	0.67	0.67 ✓	0.53
Curtain wall aluminium					
U_f [W/(m ² K)]	0.67	0.73	0.75	0.79	1.33
Ψ_g [W/(m K)]	0.067	0.066	0.070	0.070	0.094
f_{Rsi} [-]	0.80 ✓	0.78 ✓	0.76 ✓	0.76 ✓	0.64 ✓



EMBODIED CARBON

ENVIRONMENTAL PRODUCT DECLARATION

ENVIRONMENTAL PRODUCT DECLARATION

as per ISO 14025 and EN 15804+A2

Owner of the Declaration	QKE Qualitätsverband Kunststoffzeugnisse e.V. GKFP Gütegemeinschaft Kunststoff-Fensterprofilsysteme e.V. EPPA European PVC Window Profiles and related Building Products Association ivzw
Programme holder	Institut Bauen und Umwelt e.V. (IBU)
Publisher	Institut Bauen und Umwelt e.V. (IBU)
Declaration number	EPD-QKE-20220002-IBG1-EN
Issue date	03.05.2022
Valid to	02.05.2027

Plastic windows (1,23 m x 1,48 m)
with double insulating glass unit

www.ibu-epd.com | <https://epd-online.com>



AMBIANCE UPVC EPD



1. General Information

<p>QKE, GKFP, EPPA</p>	<p>Plastic windows (1,23 m x 1,48 m) with double insulating glass unit</p>
<p>Programme holder IBU – Institut Bauen und Umwelt e.V. Hegelplatz 1 10117 Berlin Germany</p>	<p>Owner of the declaration QKE – Qualitätsverband Kunststoff- erzeugnisse e.V. Am Hofgarten 1–2; 53113 Bonn Germany GKFP – Gütegemeinschaft Kunststoff- Fensterprofilssysteme e.V. Am Hofgarten 1–2; 53113 Bonn Germany EPPA – European PVC Profiles and related Building Products Association izzw Avenue de Cortenberg 71; 1000 Brussels Belgium</p>
<p>Declaration number EPD-QKE-20220002-IBG1-EN</p>	<p>Declared product / declared unit The declared unit consists of 1 m² of window surface area. The reference window is a single-sash tilt and turn window 1.23 m x 1.48 m in size with double insulating glass unit and PVC-U frame material with optional surface finishing (coated, covered with PVC foil or PMMA) and possibly additionally fitted with an aluminium covering shell. The planned replacement of individual components gasket, hardware and glazing during a 40-year service life have been included.</p>
<p>This declaration is based on the product category rules: Windows and doors, 01.2021 (PCR checked and approved by the SVR)</p>	<p>Scope: This declaration is an association EPD. It covers all constructional forms for PVC windows which comply with the stated characteristics. These are both conventionally blocked and bonded window designs and different profile reinforcement and surface design variants.</p>
<p>Issue date 03.05.2022</p>	<p>Data from the production plants of the following system suppliers and window manufacturers was included:</p>
<p>Valid to 02.05.2027</p>	<p>aluplast – Ettlingen (DE) Deceuninck – Bogen (DE), Calne (GB), Hoogled- Gits (BE), Jasin (PL), Roye (FR) GARGIULO – Nehren (DE) GEALAN – Bukarest (RO), Guopstos (LT), Rzgów (PL), Tanna (DE) hapa – Herrieden (DE) Internorm – Sarleinsbach (AT), Traun (AT) profine – Berlin (DE), Marmoutier (FR), Pirmasens (DE) REHAU – Srem (PL), Wittmund (DE) Salamander – Türkheim (DE), Wloclawek (PL) SCHÜCO – Weißenfels (DE) TMP – Bad Langensalza (DE) VEKA – Burgos (ES), Burnley (GB), Sendenhorst (DE), Skierniewice (PL), Thonon-les-Bains (FR) The weighted mean of the data from eleven member companies with 27 production sites in nine countries was used as a database for manufacturing the plastic profiles. The production quantity thus recorded corresponds to approximately 80% to the European production of the profile manufacturers who are organised in the EPPA, GKFP and QKE associations.</p>



AMBIANCE UPVC EPD



This association EPD can be used by the member companies of the three associations EPPA, GKFP and QKE as well as window manufacturers who use this company's plastic profile systems.

The owner of the declaration shall be liable for the underlying information and evidence; the IBU shall not be liable with respect to manufacturer information, life cycle assessment data and evidences.

The EPD was created according to the specifications of EN 15804+A2. In the following, the standard will be simplified as EN 15804.

Verification

The standard EN 15804 serves as the core PCR

Independent verification of the declaration and data according to ISO 14025:2011

internally externally

Dipl. Ing. Hans Peters
(chairman of Institut Bauen und Umwelt e.V.)

Dr. Alexander Röder
(Managing Director Institut Bauen und Umwelt e.V.)

Dr. Eva Schmincke
(Independent verifier)



2. Product

2.1 Product description/Product definition

Single-sash window 1.23 m x 1.48 m with PVC-U frame profiles, double insulating glass unit and tilt-turn hardware.

Steel, aluminium or glass fibre extruded into the PVC material can be used as reinforcement in the PVC profiles.

The profile surface can be made with different finishes: Uncoated white, covered with PVC foil, covered with PMMA (polymethylmethacrylate), coated or fitted with a separate aluminium covering shell. This results in white or coloured, smooth or structured surfaces.

The gaskets consist of soft PVC, EPDM (ethylene-propylene-dien monomer) or TPE (thermoplastic elastomere); the hardware are mainly made of steel.

The average window for this EPD is the white steel-reinforced basic variant. However, the inputs/outputs determined from the production quantities are included for profile production, whereby all surface finishing processes which are actually performed at the plants are included.

This EPD declares the average environmental quality for the PVC windows of the member companies of the EPPA, GKFP and QKE associations. Window manufacturers who use this company's plastic profile systems can also make use of the declaration. Detailed product data is available from the respective manufacturers' specific descriptions.

EU regulation no. 305/2011 (CPR) applies for putting the windows on the market in the EU/EFTA (with the exception of Switzerland). The product requires a declaration of performance including the harmonised product standard *DIN EN 14351-1:2016-12* Windows and doors – Product standard, performance characteristics – Part 1: Windows and external pedestrian doorsets and also CE labelling.

The respective national regulations apply to use.

2.2 Application

Windows are inserted into the outer building shell for lighting, ventilation and weather protection.

2.3 Technical Data

The figures and/or classes shown in the following table apply to the reference on which this EPD is based. Far higher classes are being achieved depending on the design of the frame, hardware, gaskets and insulating glass unit.

Name	Value	Unit
Possible opening types	tilt-turn	-
Glazing unit structure	4 / 16 / 4	mm
Total energy transmittance g	62	%
Heat transfer coefficient glass U_g in accordance with EN 674, EN 675	1.1	W/(m ² K)
Heat transfer coefficient window U_w in	1.2	W/(m ² K)

accordance with EN 674, EN 675		
Air permeability in accordance with EN 12207	2–4	Class
Resistance to wind load in accordance with EN 12210	B1–C5	Class
Water tightness in accordance with EN 12206	4A–9A	Class
Mechanical stress (durability) in accordance with EN 12400	10000–20000	Cycles

The construction details and the performance values in accordance with the declaration of performance apply to the specific window unit put on the market by the respective manufacturer with regard to their main characteristics in accordance with harmonised product standard *DIN EN 14351-1:2016-12*, Windows and doors – Product standard, performance characteristics – Part 1: Windows and external pedestrian doorsets.

2.4 Delivery status

This EPD relates to a reference window 1.23 m x 1.48 m in size.

2.5 Base materials/Ancillary materials

The main components of the reference window are:

Name	Value	Unit
25.87 kg insulating glass unit	45.2	mass %
16.79 kg frame material, PVC-U	29.3	mass %
11.87 kg reinforcement, steel	20.7	mass %
1.83 kg hardware, steel	3.2	mass %
0.76 kg gaskets, soft PVC, EPDM, TPE	1.3	mass %
0.13 kg screws, steel	0.2	mass %
0.05 kg setting blocks, PP	0.1	mass %

The following representative generic composition for the individual formulae used by the profile manufacturers for the PVC frame is included for the EPD:

- 81.0 mass % PVC
- 8.1 mass % filler (chalk)
- 4.9 mass % impact resistance modifier
- 2.8 mass % calcium-zinc-stabilisers
- 3.2 mass % titanium oxide (TiO₂) pigment

Can a partial product contain candidate materials from the *ECHA candidate list* of materials which are especially problematic for approval (as of 01/04/2020): (Substances of Very High Concern - (SVHC)) above a mass % of 0.1: Yes, the PVC profile. This may be the case if recycled PVC window material is used in the core of the product cross-section in the manufacture of this product. These profiles may contain lead compounds (CAS number 7439-92-1 of the ECHA candidate list as of 01/04/2020) at a mass of more than 0.1 %.

Does the product contain further Category 1A or 1 B CMR substances (carcinogenic, mutagenic or toxic to





reproduction) which are not on the ECHA candidate list at above 0.1 mass %: No.

Have biocidal products been added to this building product or has it been treated with biocidal products: No.

2.6 Manufacture

Plastic windows are made of the following components: PVC frame profiles with gaskets and if necessary reinforcement, insulating glass unit and hardware.

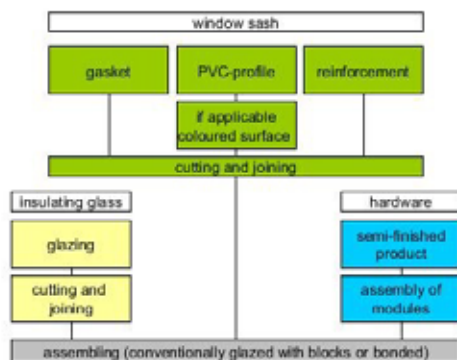

Fig. 2-1: Schematic diagram of the manufacture of a window unit

The PVC profiles are produced in an extrusion process from a mixture of PVC powder and additives. The latter protect the PVC against damage during processing and give the profile the necessary characteristics such as impact resistance, colour and weather resistance.

The PVC powder for producing the frames is a widely available mass plastic and is manufactured by polymerisation. Due to its chemical structure, PVC contains a considerable proportion of the halogen chlorine.

Coloured surfaces can be produced by fitting an aluminium covering shell, applying a foil, coating or by co-extrusion with a PMMA layer. Gaskets are either attached to the window profile in a co-extrusion process during extrusion or rolled in subsequently.

The window profiles are supplied to window manufacturers in standard lengths. There they are sawn to the lengths required for respective windows. As far as necessary, steel reinforcement is pushed in and screwed in place. The profiles are then welded, the hardware attached and the glazing and glazing beads inserted.

The steel to produce the hardware is mainly manufactured from iron ore in a furnace process through reduction with coke.

The raw material basis for the manufacture of the glazing is formed by quartz sand and the addition of various fluxing and oxidation agents (soda ash, sodium sulphate, potassium carbonate, etc.). In a further

processing step, the melted raw glass is placed in a tin melt from which a flat glass ribbon is continuously drawn (float glass process).

Quality assurance

GKFP e.V. member companies are subject to external quality control as part of voluntary self-commitment. Those plastic window profile systems which may be labelled with RAL-GZ 716 are listed on the association's website at gkfp.de/en: gkfp.de/en/product-overview/profile-systems-with-ral-quality-mark

Those window manufacturers which use the RAL quality mark in accordance with RAL-GZ 695 are also subject to external monitoring. A list is available on the Gütegemeinschaft Fenster, Fassaden und Haustüren e.V. website (window.de/guetegemeinschaft-fenster) at: ral-fachbetriebe.fenster-können-mehr.de/

2.7 Environment and health during manufacturing

Individual measures at production plants such as the implementation of an environmental or energy management system in accordance with ISO 14001 or ISO 50001 are to be found in individual company profiles.

2.8 Product processing/Installation

The finished windows are transported to the construction site and built into the building structure. Galvanised steel screws are used for installation. The use of installation foam (polyurethane) is possible.

2.9 Packaging

Cardboard, polyethylene wrap and foam pads are used to transport the individual components to the window manufacturer. The frame profiles are generally transported in reusable steel cassettes and occasionally in disposal wooden pallets.

Reusable racks are normally used to deliver the windows together with foam pads and polyethylene stretch film, cardboard and polypropylene load-securing belts and aluminium or steel clamps.

If not reused, metal packaging material is recycled; other packaging is generally thermally recycled or otherwise disposed of in landfill.

Waste code according to the *European Waste Catalogue*:

- 15 01 01 Cardboard
- 15 01 02 Plastics
- 15 01 03 Solid wood and wood-based materials
- 15 01 04 Metals

AMBIANCE UPVC EPD



2.10 Condition of use

Plastic windows are very long-lasting and durable. Their material composition does not change during use.

2.11 Environment and health during use

The environment and health are not negatively affected by the PVC frame material. This also applies to the window element as long as the use of solvent-free components is guaranteed downstream in the supply chain.

2.12 Reference service life

The service life for the product and its components is assumed as follows in accordance with *BBSR 2017*:

- 40 years for the plastic window
- 30 years for the insulating glass unit
- 30 years for the building hardware
- 20 years for the gaskets

One replacement of gaskets, hardware and glazing is included in the EPD since the service life for the components is less than that of the finished product.

2.13 Extraordinary effects

Fire

Depending on the design and surface finish, plastic windows can achieve classes E to B in accordance with *EN 13501-1* with regard to reaction to fire.

Name	Value
Building material class	E-B
Smoke production	s3
Flaming droplets	d0

Water

No effects which are detrimental to the environment occur in the event of unforeseen water exposure, such as flooding.

The watertightness of the window is influenced by the design implementation and durability of the frame profile, gasket and hardware. Different classes of water tightness are achieved accordingly (see 2.3).

Mechanical destruction

No negative effects for the environment occur on unforeseen mechanical destruction.

2.14 Re-use phase

Material recycling is easily possible and technically realised for all window components. The PVC frame

material is maintained in a controlled closed circuit and reused in window profiles after reprocessing. The steel used for hardware and reinforcements can also be recycled without any loss of quality. Material recycling is also easy for the glazing but usually associated with a loss in quality.

2.15 Disposal

The individual components of the plastic window can be incinerated as non-dangerous waste (without energy recovery) or disposed of in landfill.

Waste code according to the *European Waste Catalogue*:

- 17 02 02 Glass
- 17 02 03 Plastic
- 17 04 02 Aluminium
- 17 04 05 Iron and steel

2.16 Further information

Further information is available via the websites of the associations

www.eppa-profiles.eu
www.gkfp.de/en
www.qke-bonn.de

and also those of the system houses and window manufacturers.



3. LCA: Calculation rules

3.1 Declared Unit

The declared unit consists of 1 m² of window area on a reference window (similar to EN 14351-1 and EN 17213). Its frame area ratio F_F in relation to the overall surface area is around 28%.

Declared unit

Name	Value	Unit
Declared unit	1	m ²
Declared unit mass	31.4	kg
Reference window: Width x height	1.23 x 1.48	m
Frame area ratio	27.8	%
Mass	57.3	kg
Conversion factor reference window up to 1 m ²	0.5493	-
Conversion factor to 1kg	0.0318	-

The balanced production volume used for average calculation is based on the information from the companies named in 1 'Scope'. The underlying production process varies only slightly from one manufacturer to another. It is therefore assumed that the data is representative and robust.

3.2 System boundary

The complete lifecycle from cradle to grave is examined for the declared unit. The production stage (Modules A1–A3), the construction stage (A4, A5), the use stage (B1, B2), the disposal stage (C1–C4) and benefits and loads beyond the system boundary (D) are relevant but not the further modules of the use stage (B3, B4).

Manufacturing

The aggregated illustration in the form of A1–A3 is used for manufacturing. This includes the provision of raw materials and energy, the production of steel reinforcement, glazing, hardware and PVC profile, transport of the components to the window manufacturer, the energy consumption needed for this and accruing production waste. The consumption for heating the production plants and also the attached rooms is also specifically included. However, investment goods (machines, buildings, etc.) remain ignored.

Transport from the window manufacturer to the construction site is included in Module A4 and also the auxiliary and operating materials used for installation and the disposal of packaging waste in Module A5 in accordance with EN 17213.

Use phase

The transmission heat losses during the use phase are included in Module B1 and the replacement of window components mentioned in 2.12 in Module B2.

Disposal

All processes which relate to the removal, dismantling or demolition of the window out of the building and which are not to be regarded at building level are calculated into Module C1.

Redistribution transports from the construction site to waste treatment fall in Module C2. Waste management processes, especially energy recovery from waste, are included in Module C3. This also includes sorting for recycling.

Disposal and also thermal waste treatment are allocated to Module C4.

Credits

Finally, Module D shows the reuse, recovery and recycling potentials beyond the system boundary.

3.3 Estimates and assumptions

Average transport distances from background data will be assumed insofar as no specific information on transports is available. This especially concerns Module A2.

Dust and emissions accruing during production or disposal are examined by means of generic data.

With regard to replacing components during use and also the dismantling of the window it is assumed that the expenses are equivalent to those of installation.

3.4 Cut-off criteria

All known inputs and outputs are included in the lifecycle. Data gaps are filled with conservative assumptions and generic data. The input flows ignored are each below 1% of the total mass or the total flow of the primary energy. In total, they each represent less than 5% of the total mass or 5% of the total energy.

3.5 Background data

The modelling of the lifecycle is performed in the GaBi LCA software. The background data especially for the raw materials and the production of PVC, insulating glass unit and hardware originate from the *ecoinvent 3.7* database. As specific, current and representative data as possible is used. The data used is not more than ten years old.

3.6 Data quality

Data from twelve companies with 28 production plants in nine countries are used as primary profile extrusion and window manufacturing data, see 1 'Scope'. This data collected for 2019 was checked for plausibility and consistency. Further average information originates from the associations. The quality of the

AMBIANCE UPVC EPD



specific data is therefore to be regarded as extremely good.

At least 80% of all contributions to the core indicators of each impact category result from five background data records. Their representativeness is predominantly to be regarded as good to excellent. Data records with lower representativeness are only used in individual cases. The quality of the background data is therefore to be estimated as good overall.

3.7 Period under review

The primary data was collected for 2019.

Averages weighted with the production volume are used for production data for profile extrusion and window manufacture.

3.8 Allocation

No co-products accrue when producing the window and in further processes (Modules A1-A3). No co-product allocation is therefore necessary in foreground processes. Co-products for which an allocation is present in background data records accrue in the pre-chain for PVC, for example when producing vinyl chloride.

Energies used, auxiliary and operating materials and also waste (Modules A1-A3) are each recorded at plant level and distributed to the products across the produced mass.

Recyclates deployed (Modules A1-A3) are included in terms of a closed loop so that no allocation takes place.

In Module D, benefits and loads result from recycling PVC and metals as well as energy recovery from waste.

3.9 Comparability

Basically, a comparison or an evaluation of EPD data is only possible if all the data sets to be compared were created according to *EN 15804* and the building context, respectively the product-specific characteristics of performance, are taken into account.

This LCA was compiled with the *ecoinvent 3.7* database.



4. LCA: Scenarios and additional technical information

Characteristic product properties Information on biogenic Carbon

The total mass of biogenic carbon materials is less than 5 % of the total mass of the product and the associated packaging.

- 49 % Gas
- 25 % Heating oil
- 14 % District heating
- 12 % Other (e.g. biomass, electricity).

Basic information

The downstream technical information is the basis for the declared modules or can be used for the development of specific scenarios in the context of a building assessment if modules are not declared (MND).

Statements mainly relate to one declared unit.

Transport to the construction site (A4)

Name	Value	Unit
Specific fuel consumption per tonne kilometre	7.5 t truck	0.132 l/(t*km)
	40 t truck	0.023 l/(t*km)
Transport distance	7.5 t truck	9 km
	40 t truck	69 km

Installation into the building (A5)

The auxiliary and operating materials (e.g. fixing materials, sealants) are included in the window's LCA in accordance with EN 17213 but not the energy consumption during installation which is to be regarded at building level in the EPD, which is why this data is for information only.

Name	Value	Unit
Polyurethane installation foam	0.180	kg
Screws	0.077	kg
Electricity consumption	0.085	kWh

Use phase (B1)

The net heat losses caused by the window are included here. These consist of the transmission heat losses and the solar gains. Since these depend very strongly on actual climatic condition at the place of installation and the technical circumstances of individual building, the environmental effects stated in this EPD are merely to be regarded as examples.

The following conditions are assumed: The calculations for heat losses and gains and the results of the impact assessment are based on parameters of average European conditions. The energy demand during the use phase at the reference location is calculated in accordance with DIN V 18599-2. The following applies:

Name	Value	Unit
EU degree day factor	2135	K*d
Solar radiation	155	kWh/m ² a

The provision of heat energy is modelled as follows with German energy needs:

Maintenance (B2)

The service life for the window is calculated as 40 years in accordance with BBSR 2017. The replacement of individual components after reaching the end of their technical useful life (see 2.12) is included in B2 in accordance with EN 17213:

Name	Value	Unit
Replacement cycle : Glazing	1	Number/RSL
Gaskets	1	Number/RSL
Hardware	1	Number/RSL
Electricity consumption	0.085	kWh
Polyurethane installation foam	0.180	kg
Screws	0.077	kg

End-of-life (C1–C4)

The recycling quotas and disposal routes are country-specific and deviate strongly from one another in the European area. The LCA is based on the following assumptions:

Name	Value	Unit
Collection quota across all materials	95	%
* thereof to recycling	-	
Glass	65	%
PVC	59	%
Steel/aluminium	92	%
Other	0	%
* incineration quota of the material to be disposed of	-	
Glass	25	%
PVC	35	%
Steel/aluminium	0	%
Other	20	%
Transport distance	22	km
Dismantling electricity consumption	0.085	kWh

Reuse, recovery and recycling potential (D), relevant scenario information

The energy resulting from thermal and material recycling (thermal energy and electricity) and the recycling material accruing are credited in this module as follows:

- 10.10 kg net flow secondary glass
- 4.03 kg net flow secondary PVC
- 2.50 kg net flow secondary Steel
- 3.69 MJ exported electrical energy
- 8.15 MJ exported thermal energy

AMBIANCE UPVC EPD



5. LCA: Results

The net heat losses caused by the window are included for B1 use phase. The LCA results shown here are for information only as the losses depend very strongly on actual climatic conditions at the installation location and the technical circumstances of individual buildings.

DESCRIPTION OF THE SYSTEM BOUNDARY (X = INCLUDED IN LCA; ND = MODULE OR INDICATOR NOT DECLARED; MNR = MODULE NOT RELEVANT)

PRODUCT STAGE			CONSTRUCTION PROCESS STAGE		USE STAGE								END OF LIFE STAGE				BENEFITS AND LOADS BEYOND THE SYSTEM BOUNDARIES
Raw material supply	Transport	Manufacturing	Transport from the gate to the site	Assembly	Use	Maintenance	Repair	Replacement	Refurbishment	Operational energy use	Operational water use	De-construction demolition	Transport	Waste processing	Disposal	Reuse-Recovery-Recycling-potential	
A1	A2	A3	A4	A5	B1	B2	B3	B4	B5	B6	B7	C1	C2	C3	C4	D	
X	X	X	X	X	X	X	MNR	MNR	MNR	ND	ND	X	X	X	X	X	

RESULTS OF THE LCA - ENVIRONMENTAL IMPACT according to EN 15804+A2: 1 m² of a reference window with double insulating glass unit

Core Indicator	Unit	A1-A3	A4	A5	B1	B2	C1	C2	C3	C4	D
GWP-total	[kg CO ₂ -Eq.]	8.00E+1	3.97E-1	1.48E+0	6.09E+1	3.52E+1	1.10E-3	9.07E-2	4.10E+0	1.72E+0	-7.07E+0
GWP-fossil	[kg CO ₂ -Eq.]	7.92E+1	3.96E-1	1.44E+0	5.43E+1	3.41E+1	1.09E-3	9.04E-2	4.08E+0	3.08E-1	-6.95E+0
GWP-biogenic	[kg CO ₂ -Eq.]	7.87E-1	1.10E-3	3.54E-2	6.57E+0	1.08E+0	8.69E-6	2.19E-4	1.61E-2	1.41E+0	-1.01E-1
GWP-luluc	[kg CO ₂ -Eq.]	6.03E-2	1.63E-4	7.97E-4	9.34E-3	3.30E-2	2.36E-7	3.16E-5	5.01E-4	2.16E-5	-2.27E-2
ODP	[kg CFC11-Eq.]	1.34E-5	9.17E-8	2.01E-8	7.74E-6	3.54E-6	5.34E-10	2.08E-8	1.09E-7	2.56E-8	-2.54E-6
AP	[mol H ⁺ -Eq.]	4.60E-1	1.18E-3	5.88E-3	9.45E-2	2.48E-1	1.07E-5	5.08E-4	2.65E-3	6.64E-4	-3.45E-2
EP-freshwater	[kg P-Eq.]	3.13E-2	3.20E-5	2.17E-4	2.98E-3	1.03E-2	6.82E-8	6.37E-6	2.38E-4	2.59E-5	-3.97E-3
EP-marine	[kg N-Eq.]	8.86E-2	2.53E-4	1.89E-3	1.66E-2	4.88E-2	4.06E-6	1.86E-4	8.48E-4	3.84E-3	-6.51E-3
EP-terrestrial	[mol N-Eq.]	8.48E-1	2.74E-3	1.11E-2	1.76E-1	4.90E-1	4.45E-5	2.03E-3	6.87E-3	2.48E-3	-6.23E-2
POCP	[kg NMVOC-Eq.]	2.76E-1	1.07E-3	3.97E-3	6.61E-2	1.45E-1	1.27E-5	5.80E-4	1.93E-3	1.09E-3	-2.01E-2
ADPE	[kg Sb-Eq.]	1.26E-3	1.68E-6	7.72E-6	1.05E-4	8.08E-4	2.06E-9	3.13E-7	3.66E-6	2.54E-7	-5.86E-4
ADPF	[MJ]	1.38E+3	6.26E+0	2.13E+1	7.95E+2	4.76E+2	3.52E-2	1.40E+0	7.72E+0	1.90E+0	-1.54E+2
WDP	[m ³ world-Eq deprived]	4.29E+1	3.43E-2	1.07E+0	2.18E+0	1.53E+1	1.83E-3	6.93E-3	4.21E+0	9.73E-2	-6.15E+0

Caption: GWP = Global warming potential; ODP = Depletion potential of the stratospheric ozone layer; AP = Acidification potential of land and water; EP = Eutrophication potential; POCP = Formation potential of tropospheric ozone photochemical oxidants; ADPE = Abiotic depletion potential for non-fossil resources; ADPF = Abiotic depletion potential for fossil resources; WDP = Water (user) deprivation potential

RESULTS OF THE LCA - INDICATORS TO DESCRIBE RESOURCE USE according to EN 15804+A2: 1 m² of a reference window with double insulating glass unit

Indicator	Unit	A1-A3	A4	A5	B1	B2	C1	C2	C3	C4	D
PERE	[MJ]	7.19E+1	9.69E-2	9.62E-1	2.29E+1	3.07E+1	6.99E-4	1.92E-2	6.94E+0	9.70E-2	-1.09E+1
PERM	[MJ]	9.26E+0	0.00E+0	0.00E+0	0.00E+0	0.00E+0	0.00E+0	0.00E+0	-9.26E+0	0.00E+0	0.00E+0
PERT	[MJ]	8.12E+1	9.69E-2	9.62E-1	2.29E+1	3.07E+1	6.99E-4	1.92E-2	-2.32E+0	9.70E-2	-1.09E+1
PENRE	[MJ]	1.14E+3	6.26E+0	2.14E+1	7.95E+2	4.76E+2	3.52E-2	1.40E+0	1.73E+2	1.90E+0	-3.92E+1
PENRM	[MJ]	2.37E+2	0.00E+0	0.00E+0	0.00E+0	0.00E+0	0.00E+0	0.00E+0	-1.22E+2	0.00E+0	-1.14E+2
PENRT	[MJ]	1.38E+3	6.26E+0	2.14E+1	7.95E+2	4.76E+2	3.52E-2	1.40E+0	5.07E+1	1.90E+0	-1.54E+2
SM	[kg]	7.32E+0	0.00E+0	4.31E-2	0.00E+0	1.21E+0	0.00E+0	0.00E+0	0.00E+0	0.00E+0	1.81E+1
RSF	[MJ]	0.00E+0	0.00E+0	0.00E+0	0.00E+0	0.00E+0	0.00E+0	0.00E+0	0.00E+0	0.00E+0	0.00E+0
NRSF	[MJ]	0.00E+0	0.00E+0	0.00E+0	0.00E+0	0.00E+0	0.00E+0	0.00E+0	0.00E+0	0.00E+0	0.00E+0
FW	[m ³]	9.98E-1	7.99E-4	2.49E-2	5.08E-2	3.55E-1	4.26E-5	1.61E-4	9.80E-2	2.27E-3	-1.43E-1

Caption: PERE = Use of renewable primary energy excluding renewable primary energy resources used as raw materials; PERM = Use of renewable primary energy resources used as raw materials; PERT = Total use of renewable primary energy resources; PENRE = Use of non-renewable primary energy excluding non-renewable primary energy resources used as raw materials; PENRM = Use of non-renewable primary energy resources used as raw materials; PENRT = Total use of non-renewable primary energy resources; SM = Use of secondary material; RSF = Use of renewable secondary fuels; NRSF = Use of non-renewable secondary fuels; FW = Use of net fresh water

RESULTS OF THE LCA - WASTE CATEGORIES AND OUTPUT FLOWS according to EN 15804+A2: 1 m² of a reference window with double insulating glass unit

Indicator	Unit	A1-A3	A4	A5	B1	B2	C1	C2	C3	C4	D
HWD	[kg]	7.56E-6	0.00E+0	0.00E+0	0.00E+0	0.00E+0	0.00E+0	0.00E+0	0.00E+0	0.00E+0	0.00E+0
NHWD	[kg]	1.68E-1	0.00E+0	0.00E+0	0.00E+0	4.34E+0	2.58E-1	0.00E+0	0.00E+0	7.98E+0	0.00E+0
RWD	[kg]	6.60E-3	0.00E+0	0.00E+0	0.00E+0	0.00E+0	0.00E+0	0.00E+0	0.00E+0	0.00E+0	0.00E+0
CRU	[kg]	0.00E+0	0.00E+0	0.00E+0	0.00E+0	0.00E+0	0.00E+0	0.00E+0	0.00E+0	0.00E+0	0.00E+0
MFR	[kg]	3.56E+0	0.00E+0	0.00E+0	0.00E+0	9.20E+0	0.00E+0	0.00E+0	2.02E+1	0.00E+0	0.00E+0
MER	[kg]	0.00E+0	0.00E+0	0.00E+0	0.00E+0	0.00E+0	0.00E+0	0.00E+0	0.00E+0	0.00E+0	0.00E+0
EEE	[MJ]	0.00E+0	0.00E+0	0.00E+0	0.00E+0	0.00E+0	0.00E+0	0.00E+0	3.68E+0	0.00E+0	0.00E+0
EET	[MJ]	0.00E+0	0.00E+0	0.00E+0	0.00E+0	0.00E+0	0.00E+0	0.00E+0	8.15E+0	0.00E+0	0.00E+0

Caption: HWD = Hazardous waste disposed; NHWD = Non-hazardous waste disposed; RWD = Radioactive waste disposed; CRU = Components for re-use; MFR = Materials for recycling; MER = Materials for energy recovery; EEE = Exported electrical energy; EET = Exported thermal energy

AMBIANCE UPVC EPD



RESULTS OF THE LCA – additional impact categories according to EN 15804+A2-optional: 1 m² of a reference window with double insulating glass unit

Indicator	Unit	A1-A3	A4	A5	B1	B2	C1	C2	C3	C4	D
PM	[Disease Incidence]	4.36E-6	2.74E-8	1.07E-7	7.54E-7	2.46E-6	2.33E-10	8.14E-9	1.67E-8	1.39E-8	-2.35E-7
IRP	[kBq U235-Eq.]	9.10E+0	3.33E-2	2.83E-2	2.36E+0	2.93E+0	1.75E-4	7.29E-3	1.07E-1	1.33E-2	-9.75E-1
ETP-fw	[CTUe]	3.14E+3	5.19E+0	5.81E+1	4.58E+2	2.26E+3	1.90E-2	1.12E+0	1.95E+2	1.73E+1	-2.75E+2
HTP-c	[CTUh]	2.47E-7	1.87E-10	1.55E-9	1.14E-8	4.49E-8	5.41E-13	4.70E-11	6.60E-10	1.07E-10	-1.02E-8
HTP-nc	[CTUh]	1.40E-6	4.30E-9	2.65E-8	1.85E-7	6.05E-7	8.41E-12	1.09E-9	5.12E-8	3.07E-9	-2.13E-7
SQP	[.]	2.99E+2	5.38E+0	1.93E+0	1.25E+2	1.34E+2	7.88E-2	1.19E+0	2.73E+0	4.13E+0	-2.95E+1
Caption	PM = Potential incidence of disease due to PM emissions; IR = Potential Human exposure efficiency relative to U235; ETP-fw = Potential comparative Toxic Unit for ecosystems; HTP-c = Potential comparative Toxic Unit for humans (cancerogenic); HTP-nc = Potential comparative Toxic Unit for humans (not cancerogenic); SQP = Potential soil quality index										

Important

EP fresh water: This indicator was implemented in co-ordination with the characterisation module (EUTREND model, Struijs et al., 2009b, as in ReCiPe; <http://epca.jrc.ec.europa.eu/LCDN/developerEF.xhtml>) calculated as “kg P-Eq”.

Disclaimer 1 – applies to the indicator IR “Potential Human exposure efficiency relative to U235”

This impact category mainly deals with the possible impact of low-dose ionizing radiation on human health in the nuclear fuel cycle. It does not consider neither impacts due to possible nuclear accidents, occupational exposure nor due to radioactive waste disposal in underground facilities. The potential ionizing radiation emanating from the soil, from radon and from some construction materials is also not measured by this indicator.

Disclaimer 2 – applies to the indicators ADPE, ADPF, WDP, ETP-fw, HTP-c, HTP-nc, SQP “abiotic depletion potential for non-fossil resources”, “abiotic depletion potential for fossil resources”, “water (user) deprivation potential, deprivation-weighted water consumption”, “potential comparative toxic unit for ecosystems”, “potential comparative toxic unit for humans – cancerogenic”, “Potential comparative toxic unit for humans - not cancerogenic”, “potential soil quality index”.

The results of this environmental impact indicator shall be used with care as the uncertainties with these results are high or because there is limited experienced with the indicator.

6. LCA: Interpretation

6.1 Summary

Many of the environmental impact and resource use indicators are dominated by the manufacturing phase (Modules A1–A3). In addition, the energy consumption needed to compensate heat losses through the window (Module B1), maintenance (Module B2) and to a lesser extent waste treatment (Module C3) take a major share of the indicators.

The impacts within the system boundary can be compensated by recovery and recycling potentials beyond the system boundary (Module D).

Within Modules A1–A3 the insulating glass unit, the metal components and the PVC dryblend contribute to the results to a similar extent.

Sensitivity observations show that different window designs (e.g. with regard to reinforcement material or also in relation to the dimensions) and also the surface design influence the environmental impacts of the manufacturing phase at least within the range up to ± 10%.

The largest contribution in Module B2 originates from the replacement of the glazing.

The declaration of Module B1 is optional for windows. However, since these have a significant influence on the energy household of a building it makes sense to assess their use phase. The values declared for B1 apply to the exemplary application case specified in Section 4 and are for information only. Optimisation would involve reducing transmission heat losses determined by the heat transfer coefficients and to optimise the solar gains (e.g. through alignment and shadows).

6.2 Sensitivity to the use of PVC recycle

The impacts described above caused by the PVC frame material used change with the PVC recycle rate. The environmental impacts decrease in Modules A1–A3 if fresh PVC material is replaced by recycle. In case of a share of 40% the effects here decrease by 6% on average (range -3% to -25%).

Furthermore, an increase in the proportion of recycle in the profile results in assessment differences in Module C3 (PENRM indicator) and also smaller benefits in Module D due to the reduced quantity of PVC recycle which crosses the system boundary. This drops on average by 24% with a 40% share of recycle (range -51% to +9%).

Fig. 6-1 shows how greatly the total GKWP indicator in Module A1–A3 is reduced by an increase in recycle content. The recycle content determined for 2019 was approximately 21%.

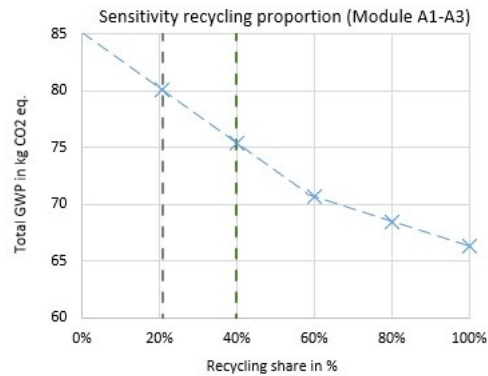

Fig. 6-1: Total GWP of the window manufacturing module (A1–A3) depending on the recycle content

The use of PVC recycle in the profile is, however, limited. On the one hand because unlimited amounts of recycling material are not available and on the other due to the profile design, where design or quality-related requirements can make the use of fresh material necessary.

A maximum of 40% PVC recycle in relation to the annual tonnage of profile production appears technically realisable under these framework conditions. Individual profiles can contain a significantly higher proportion of recycle in spite of this.

6.3 Isolated view of the impact indicators and their influencing factors

6.3.1 Environmental impacts

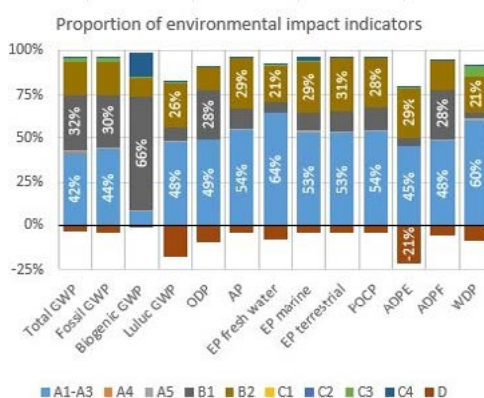

Fig. 6-2: Indicators to describe the environmental impacts, distribution per module



Global warming potential (GWP)

Greenhouse gas emissions are above all attributable to production, energy consumption in the use phase and maintenance. The most relevant greenhouse gases are carbon dioxide (fossil 83%, biogenic 9%) and methane (fossil 8%, biogenic 1%). The effects of land use changes are extremely low.

Depletion potential of the stratospheric ozone layer (ODP)

Impacts on ozone depletion mainly result from the production phase and energy consumption in the use phase. Emissions of halon 1301, halon 1211 and tetrachloromethane are mainly responsible for this.

Acidification potential of land and water (AP)

Acidification potential results above all from emissions of nitrogen oxides and sulphur oxides which occur during the production phase, maintenance and the use phase.

Eutrophication potential (EP)

The impacts on the eutrophication of water and soil originates above all from the production phase, maintenance and energy consumption in the use phase. The relevant emissions are phosphates and nitrogen oxides.

Formation potential for tropospheric ozone photochemical oxidants (POCD)

Ozone formation close to the ground is above all attributable to the production, maintenance and use phases. The relevant emissions are nitrogen oxides and volatile organic compounds without methane (NMVOC).

Abiotic depletion potential for non-fossil resources (ADPE)

The consumption of non-fossil resources results above all from production, maintenance and also use to a lesser extent. Consumption can be partly compensated beyond the system boundary (substitution of primary material). The elements which make the greatest contribution are tellurium, lead, silver, gold, zinc and copper.

Abiotic depletion potential for fossil resources (ADPF)

Fossil resources are consumed above all through the use of energy in production, use and maintenance. This concerns above all natural gas, oil and coal energy carriers.

Use of water (WDP)

Use of water results above all from energy production with hydro-electric power for production, maintenance and use. Water is, however, actually consumed in the provision of the raw materials - glass, steel and PVC.

6.3.2 Use of resources

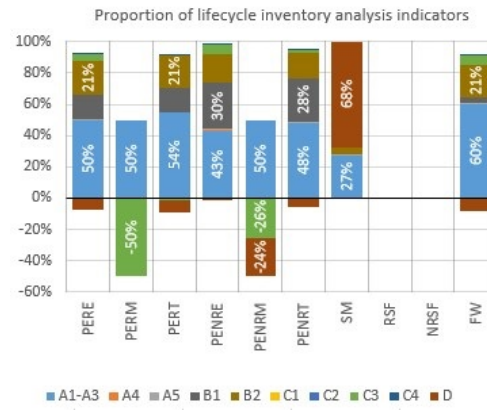

Fig. 6-3: Indicators to describe the use of resources

Renewable primary energy as energy carrier (PERE) and for material use (PERM)

Renewable primary energy is used above all energetically in the production, maintenance and use phases. This is mainly biomass and hydro-electric and wind power. Material use, on the other hand, plays a smaller role; effects result from the stabiliser used.

Non-renewable primary energy as energy carrier (PENRE) and for material use (PENRM)

Non-renewable primary energy is also mainly used as energy; consumption of gas, oil and coal in the use, production and maintenance phases is relevant here. Material use in new PVC is of less significance.

Use of secondary materials (SM)

Secondary materials are used for the provision of metal components, especially steel, and also PVC and glass. Secondary materials in Module D are also provided for use beyond the system boundary.

Secondary fuels (RSF, NRSF)

The results are only partly significant due to methodical limitations. Secondary fuels are not used within the processes and data included.

Use of net fresh water (FW)

Use of water is used above all for energy production with hydro-electric power for production, maintenance and use. The consumption of fresh water results above all from the production of raw materials - glass, steel and PVC.

6.3.3 Output flows and waste categories

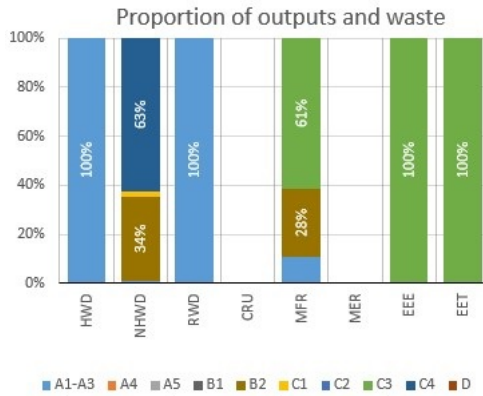

Fig. 6-4: Waste categories and output flows

Hazardous waste disposal (HWD)

The results are only partly significant due to methodical limitations. Small quantities of hazardous waste are deposited in PVC production and its pre-chains.

Non-hazardous waste disposal (NHWD)

The results are only partly significant due to methodical limitations. Non-hazardous waste accrues above all from waste disposal (Module C4) and maintenance. This is mainly deposited glass waste. On the other hand, the contribution from PVC production is extremely small.

Radioactive waste disposal (RWD)

The results are only partly significant due to methodical limitations. Contributions result from electricity shares from nuclear energy including in PVC production.

Components for reuse (CRU)

Nothing accrues.

Materials for recycling (MFR)

Materials for recycling are provided above all by waste treatment (Module C3), maintenance and to a lesser extent by recycling production waste. This is glass, metal and PVC.

Materials for energy recovery (MER)

Nothing accrues.

Exported energy (EEE, EET)

Energy in the form of electricity (EEE) and heat (EET) is recovered especially from waste treatment and exported, and here above all by incinerating PVC waste.

6.3.4 Additional impact categories

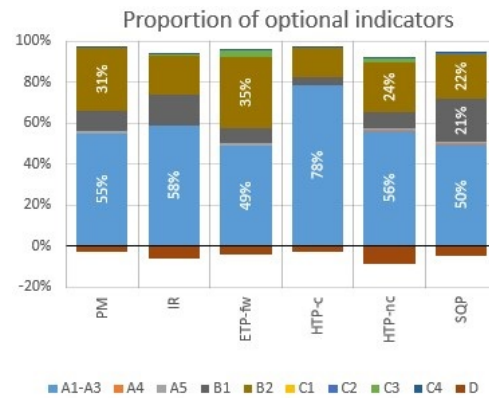

Fig. 6-5: Additional impact categories in accordance with EN 15804+A2

The distribution of further indicators to be stated optionally in individual modules of the lifecycle in accordance with EN 15804+A2 can be seen in Fig. 6-5. There is no discussion.

7. Requisite evidence

7.1 Fire behaviour

Fire tests in accordance with *EN 13823* on several samples from various manufacturers by Efectis Nederland BV, project number 2012-Efectis-R0205

Results:

In accordance with the average parameters determined, plastic windows fulfil the classification criteria in accordance with *DIN EN 13501-1*:

2007+A1:2009 as follows:

Fire behaviour class: B-E

Smoke production: s3

Flaming droplets: d0

7.2 VOC emissions

7.2.1

Final Report VOC Emission Study 'Plastic Windows'

Institut für Holztechnologie Dresden gemeinnützige GmbH (IHD). NO 1516009. July 2017

The results of several examinations of indoor pollution with VOC emissions are summarised in the report.

Results:

With regard to the French *Décret n° 2011-321* VOC ordinance for building products, all window elements examined fulfilled the best possible class A+ according to *Arrêté étiquetage 2011*.

With regard to the *AgBB* German assessment schema, all PVC frame profile variants examined (white, coated, foil-covered) fulfil the requirements.

7.2.2

Research project on VOC emissions in building components

The Federal Office for Building and Regional Planning (BBR) as part of the research initiative on the future of building (Bundesamt für Bauwesen und Raumordnung im Rahmen der Forschungsinitiative Zukunft Bau), file ref. Z6-10.08.18.7-08.20/II2-F20-08-005; December 2010

Results: With regard to indoor pollution, the requirements of the assessment by the *AgBB* schema are undercut.



8. References

STANDARDS

DIN 4102-1

DIN 4102-1:1998-05, Fire behaviour of building materials and building components – Part 1: Building materials; concepts, requirements and tests.

DIN V 18599-2

DIN V 18599-2:2011-12, Energy efficiency of buildings – Calculation of the net, final and primary energy demand for heating, cooling, ventilation, domestic hot water and lighting – Part 2: Net energy demand for heating and cooling of building zones.

EN 13501-1

DIN EN 13501-1:2019-05, Fire classification of construction products and building elements – Part 1: Classification using data from reaction to fire tests.

EN 13823

DIN EN 13823:2020-09, Reaction to fire tests for building products – Building products excluding floorings exposed to the thermal attack by a single burning item.

EN 14351-1

DIN EN 14351-1:2016-12, Windows and doors – Product standard, performance characteristics – Part 1: Windows and external pedestrian doorsets.

EN 15804

DIN EN 15804:2020-03, Sustainability of construction works – Environmental product declarations – Core rules for the product category of construction products. German version EN 15804:2012+A2:2019

EN 17213

DIN EN 17213:2020-09, Windows and doors – Environmental Product Declarations – Product category rules for windows and pedestrian doorsets.

ISO 14001

DIN EN ISO 14001:2015-11, Environmental management systems – Requirements with guidance for use.

ISO 14025

DIN EN ISO 14025:2011-10, Environmental labels and declarations – Type III environmental declarations – Principles and procedures.

ISO 50001

DIN EN ISO 50001:2018-12: Energy management systems – Requirements with guidance for use

FURTHER REFERENCES

AgBB

Evaluation scheme of emissions of Volatile Organic Compounds from building products; Committee for the Health-related Evaluation of Building Products; Germany, June 2021.

Arrêté étiquetage 2011

Arrêté du 19 avril 2011 relatif à l'étiquetage des produits de construction ou de revêtement de mur ou de sol et des peintures et vernis sur leurs émissions de polluants volatils. (JORF n°0111 du 13 mai 2011. Texte n° 15).

This decree specifies the details of the VOC regulation Décret n° 2011-321 including the limit values of the classes and the type of labeling.

BBSR 2017

Federal Institute for Construction, Urban and Regional Research, 24.02.2017, Useful lives of building components for life-cycle analysis according to BNB.

Construction Products Regulation (CPR)

Regulation (EU) No 305/2011 of the European Parliament and of the Council of 9 March 2011 laying down harmonised conditions for the marketing of construction products and repealing Council Directive 89/106/EEC (OJ L 88, 4.4.2011, p. 5–43).

Décret n° 2011-321

Décret n° 2011-321 du 23 mars 2011 relatif à l'étiquetage des produits de construction ou de revêtement de mur ou de sol et des peintures et vernis sur leurs émissions de polluants volatils (JORF n°0071 du 25 mars 2011. Texte n° 16).

French regulation on the labeling of construction products with regard to their emissions of volatile pollutants (VOC emissions).

ECHA candidate list

Candidate List of substances of very high concern for Authorisation (published in accordance with Article 59(10) of the REACH Regulation), 01.04.2020. Helsinki: European Chemicals Agency (ECHA).

ecoinvent 3

ecoinvent 3.7. Version 3.7.1, 2020. Dübendorf (CH): Swiss Centre for Life Cycle Inventories.

European Waste Catalogue

European Waste Catalogue (EWC) (Commission Decision 94/3/EC).

Gabi

GaBi ts, Version 10.5, 2021. Software-System and Database. Leinfelden-Echterdingen: Sphera Solutions GmbH.

IBU 2021/1

Institut Bauen und Umwelt e.V., 2021: General Instructions for the EPD programme of Institut Bauen und Umwelt e.V., Version 2.0, Berlin: Institut Bauen und Umwelt e.V.

AMBIANCE UPVC EPD



IBU 2021/2

Institut Bauen und Umwelt e.V., 2021: Product Category Rules for Building-Related Products and Services. Institut Bauen und Umwelt e.V. (IBU) Part A: Calculation Rules for the Life Cycle Assessment and Requirements on the Project Report acc. to EN 15804+A2:2019. Version 1.1. Berlin: Institut Bauen und Umwelt e.V.

IBU 2021/3

Institut Bauen und Umwelt e.V., 2021: PCR Guidance-Texts for Building-Related Products and Services. From the range of Environmental Product Declarations of Institute Construction and Environment e.V. (IBU) Part B: Requirements on the EPD for Windows and Doors. Version 1.4. Berlin: Institut Bauen und Umwelt e.V.

ift 2010

ift Rosenheim 2010: Research project on VOC emissions in building components. Sponsored by The Federal Office for Building and Regional Planning (BBR) as part of the research initiative on the future of building (Bundesamt für Bauwesen und Raumordnung im Rahmen der Forschungsinitiative Zukunft Bau), file ref. Z6-10.08.18.7-08.20/II2-F20-08-005; Rosenheim: ift Rosenheim, Hochschule Rosenheim.

RAL-GZ 695

RAL Deutsches Institut für Gütesicherung und Kennzeichnung e.V. 2016: Windows, facades and front doors - Quality certification (RAL-GZ 695). Bonn: RAL Deutsches Institut für Gütesicherung und Kennzeichnung e.V.

RAL-GZ 716

RAL Deutsches Institut für Gütesicherung und Kennzeichnung e.V., 2019: Plastic window profile systems - Quality certification (RAL-GZ 716). Bonn: RAL Deutsches Institut für Gütesicherung und Kennzeichnung e.V.

AMBIANCE UPVC EPD



Publisher
 Institut Bauen und Umwelt e.V.
 Hegelplatz 1
 10117 Berlin
 Germany

Tel +49 (0)30 3087748- 0
 Fax +49 (0)30 3087748- 29
 Mail info@ibu-epd.com
 Web www.ibu-epd.com



Programme holder
 Institut Bauen und Umwelt e.V.
 Hegelplatz 1
 10117 Berlin
 Germany

Tel +49 (0)30 - 3087748- 0
 Fax +49 (0)30 - 3087748 - 29
 Mail info@ibu-epd.com
 Web www.ibu-epd.com



Author of the Life Cycle Assessment
 SKZ - Das Kunststoff-Zentrum
 Friedrich-Bergius-Ring 22
 97076 Würzburg
 Germany

Tel +49 931 4104-433
 Fax +49 931 4104-707
 Mail kfe@skz.de
 Web www.skz.de



Owner of the Declaration
 GKFP - Gütegemeinschaft
 Kunststoff-Fensterprofilesysteme
 e.V.
 Am Hofgarten 1-2
 53113 Bonn
 Germany

Tel +49 228 766 76 54
 Fax +49 228 766 76 50
 Mail info@gkfp.de
 Web gkfp.de

EPPA - European PVC Profiles
 and related Building Products
 Association
 Avenue de Cortenbergh 71
 1000 Brüssel
 Belgium

Tel +32 27 39 63 81
 Fax +32 27 32 42 18
 Mail info@eppa-profiles.eu
 Web eppa-profiles.eu

QKE - Qualitätsverband
 Kunststoffherzeugnisse e.V.
 Am Hofgarten 1-2
 53113 Bonn
 Germany

Tel +49 (0)228 7667654
 Fax +49 (0)228 7667650
 Mail info@qke-bonn.de
 Web qke-bonn.de



Span Charts

14x341 Mullion

- ▶ Spans are the maximum calculated allowable, based on the revised NZS 4211, which requires that the member deflection at serviceability wind press (SWP) should not exceed 1/200 of the span.
- ▶ All spans have been calculated to indicate performance in each wind zone. Current NZS 4211 compliance should be checked against the latest aluplast reports and size limits imposed by NZS 4211, Section 5.2.2, should not be exceeded.
- ▶ Any custom calculations can be performed as required on request.

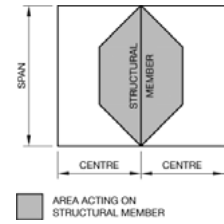

Centers	Spans for each wind zone				
	Low 510pa	Medium 680pa	High 970pa	Very High 1250pa	Extra High 1515pa
600	2110	1920	1710	1580	1480
700	2005	1840	1635	1515	1425
800	1935	1770	1580	1450	1385
900	1880	1710	1545	1420	1360
1000	1815	1680	1520	1400	1330
1100	1795	1660	1475	1385	1300
1200	1775	1615	1465	1385	1295
1300	1730	1605	1465	1365	1295
1400	1725	1605	1465	1355	1230
1500	1725	1575	1440	1285	1170
1600	1695	1575	1365	1220	1120
1700	1695	1510	1305	1170	1080
1800	1630	1440	1250	1130	1055

14x341 with 229101

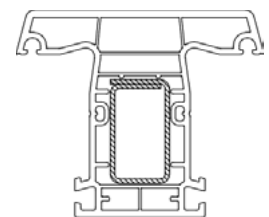

Centers	Spans for each wind zone				
	Low 510pa	Medium 680pa	High 970pa	Very High 1250pa	Extra High 1515pa
600	2345	2130	1895	1740	1645
700	2230	2025	1815	1670	1565
800	2150	1955	1755	1615	1515
900	2070	1900	1690	1580	1480
1000	2020	1835	1660	1535	1460
1100	1995	1810	1640	1505	1445
1200	1935	1795	1600	1495	1410
1300	1920	1745	1585	1495	1405
1400	1875	1740	1585	1470	1405
1500	1875	1740	1575	1470	1340
1600	1875	1710	1565	1395	1275
1700	1845	1710	1490	1330	1220
1800	1845	1645	1420	1280	1200

14x341 with 229098

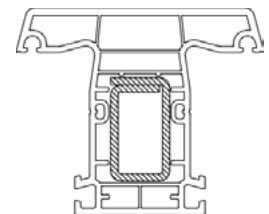

Centers	Spans for each wind zone				
	Low 510pa	Medium 680pa	High 970pa	Very High 1250pa	Extra High 1515pa
600	2610	2385	2115	1945	1825
700	2490	2265	2010	1865	1750
800	2385	2185	1940	1785	1690
900	2315	2100	1885	1735	1635
1000	2235	2050	1820	1705	1600
1100	2185	2000	1800	1685	1580
1200	2165	1965	1780	1635	1570
1300	2110	1950	1735	1630	1525
1400	2095	1905	1730	1630	1525
1500	2050	1905	1730	1595	1525
1600	2050	1880	1700	1595	1465
1700	2010	1875	1700	1530	1395
1800	2010	1875	1635	1460	1370

14x341 with 229098 and 259023

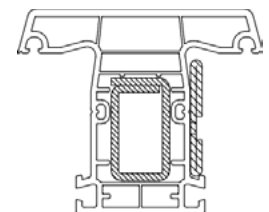

14x345 Mullion

- ▶ Spans are the maximum calculated allowable, based on the revised NZS 4211, which requires that the member deflection at serviceability wind press (SWP) should not exceed 1/200 of the span.
- ▶ All spans have been calculated to indicate performance in each wind zone. Current NZS 4211 compliance should be checked against the latest aluplast reports and size limits imposed by NZS 4211, Section 5.2.2, should not be exceeded.
- ▶ Any custom calculations can be performed as required on request.

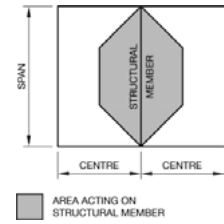

Centers	Spans for each wind zone				
	Low 510pa	Medium 680pa	High 970pa	Very High 1250pa	Extra High 1515pa
600	2840	2715	2410	2230	2090
700	2840	2595	2305	2120	2000
800	2730	2480	2225	2045	1915
900	2625	2410	2140	1985	1865
1000	2560	2325	2090	1920	1815
1100	2480	2275	2025	1895	1775
1200	2435	2210	2000	1845	1760
1300	2370	2195	1985	1825	1730
1400	2355	2150	1940	1820	1710
1500	2305	2135	1935	1780	1710
1600	2300	2130	1895	1780	1680
1700	2265	2090	1895	1780	1680
1800	2260	2090	1875	1775	1665

14x345 with 249035

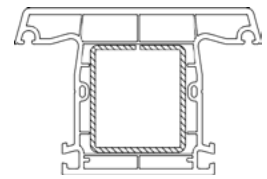

Centers	Spans for each wind zone				
	Low 510pa	Medium 680pa	High 970pa	Very High 1250pa	Extra High 1515pa
600	2860	2860	2555	2360	2215
700	2860	2750	2440	2245	2105
800	2860	2630	2335	2165	2030
900	2785	2550	2265	2085	1975
1000	2710	2465	2210	2035	1905
1100	2625	2415	2145	2000	1880
1200	2580	2345	2120	1950	1845
1300	2510	2325	2065	1935	1815
1400	2495	2270	2055	1885	1810
1500	2440	2260	2005	1885	1770
1600	2435	2210	2005	1880	1770
1700	2385	2210	1970	1860	1745
1800	2385	2175	1970	1860	1745

14x345 with 249035 and 259023

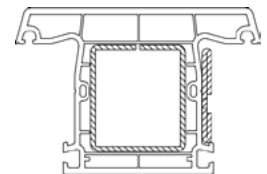

Centers	Spans for each wind zone				
	Low 510pa	Medium 680pa	High 970pa	Very High 1250pa	Extra High 1515pa
600	2860	2860	2860	2860	2860
700	2860	2860	2860	2860	2815
800	2860	2860	2860	2860	2705
900	2860	2860	2860	2775	2605
1000	2860	2860	2860	2705	2535
1100	2860	2860	2850	2620	2455
1200	2860	2860	2770	2575	2415
1300	2860	2860	2725	2505	2360
1400	2860	2860	2660	2490	2335
1500	2860	2860	2650	2435	2305
1600	2860	2860	2590	2430	2275
1700	2860	2860	2590	2380	2265
1800	2860	2805	2540	2380	2240

14x345 with 249035 and 259926

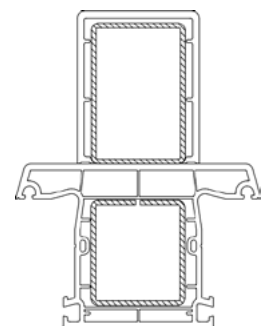

14x341 Mullion with Static Post 12x109

- ▶ Spans are the maximum calculated allowable, based on the revised NZS 4211, which requires that the member deflection at serviceability wind press (SWP) should not exceed 1/200 of the span.
- ▶ All spans have been calculated to indicate performance in each wind zone. Current NZS 4211 compliance should be checked against the latest aluplast reports and size limits imposed by NZS 4211, Section 5.2.2, should not be exceeded.
- ▶ Any custom calculations can be performed as required on request.

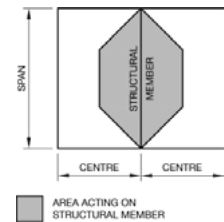

Centers	Spans for each wind zone				
	Low 510pa	Medium 680pa	High 970pa	Very High 1250pa	Extra High 1515pa
600	2860	2860	2805	2580	2420
700	2860	2860	2680	2465	2310
800	2860	2860	2565	2355	2230
900	2860	2775	2490	2290	2145
1000	2860	2705	2405	2220	2095
1100	2860	2620	2355	2165	2000
1200	2805	2575	2285	2140	2000
1300	2760	2505	2270	2085	1995
1400	2690	2490	2215	2075	1945
1500	2680	2435	2205	2025	1940
1600	2625	2430	2160	2025	1900
1700	2615	2380	2160	2000	1900
1800	2570	2380	2120	2000	1890

**12x109 with 229125
14x341 with 229101**

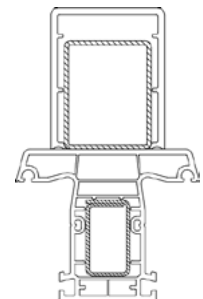

Centers	Spans for each wind zone				
	Low 510pa	Medium 680pa	High 970pa	Very High 1250pa	Extra High 1515pa
600	2860	2860	2860	2860	2720
700	2860	2860	2860	2770	2600
800	2860	2860	2860	2650	2485
900	2860	2860	2770	2570	2410
1000	2860	2860	2700	2485	2330
1100	2860	2860	2615	2430	2280
1200	2860	2860	2570	2360	2215
1300	2860	2815	2505	2345	2200
1400	2860	2750	2490	2285	2150
1500	2860	2725	2430	2275	2135
1600	2860	2680	2425	2230	2130
1700	2860	2625	2375	2230	2095
1800	2835	2625	2375	2190	2095

**12x109 with 229125
14x341 with 229101**

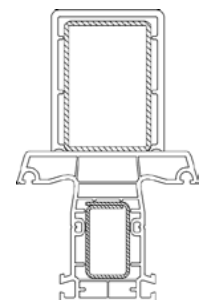

Centers	Spans for each wind zone				
	Low 510pa	Medium 680pa	High 970pa	Very High 1250pa	Extra High 1515pa
600	2860	2860	2860	2860	2770
700	2860	2860	2860	2805	2645
800	2860	2860	2860	2700	2530
900	2860	2860	2825	2595	2460
1000	2860	2860	2755	2530	2375
1100	2860	2860	2665	2450	2325
1200	2860	2860	2620	2405	2255
1300	2860	2860	2550	2360	2240
1400	2860	2800	2525	2330	2185
1500	2860	2735	2475	2305	2175
1600	2860	2730	2460	2270	2130
1700	2860	2675	2420	2265	2130
1800	2860	2675	2400	2230	2115

**12x109 with 259926
14x341 with 229098**

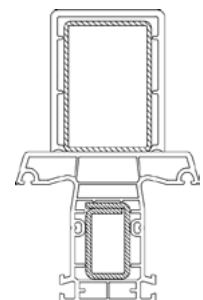

14x341 Mullion and 14x320 Tilt & Turn Sash

- ▶ This sheet is only applicable if the profile combination is continuous from head to sill and not applicable if fixed light above or below.
- ▶ Spans are the maximum calculated allowable, based on the revised NZS 4211, which requires that the member deflection at serviceability wind press (SWP) should not exceed 1/200 of the span.
- ▶ All spans have been calculated to indicate performance in each wind zone. Current NZS 4211 compliance should be checked against the latest aluplast reports and size limits imposed by NZS 4211, Section 5.2.2, should not be exceeded.
- ▶ Any custom calculations can be performed as required on request.

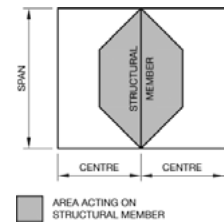

Centers	Spans for each wind zone				
	Low 510pa	Medium 680pa	High 970pa	Very High 1250pa	Extra High 1515pa
600	2565	2345	2085	1915	1795
700	2450	2225	1995	1835	1720
800	2345	2150	1910	1775	1668
900	2275	2070	1855	1705	1630
1000	2220	2020	1815	1680	1575
1100	2150	1990	1770	1655	1555
1200	2130	1935	1750	1610	1545
1300	2075	1920	1730	1600	1525
1400	2065	1875	1700	1600	1505
1500	2015	1870	1700	1575	1505
1600	2015	1870	1685	1575	1440
1700	2000	1845	1685	1505	1375
1800	1995	1845	1610	1435	1350

**14x341 with 229101
14x320 with 249016**

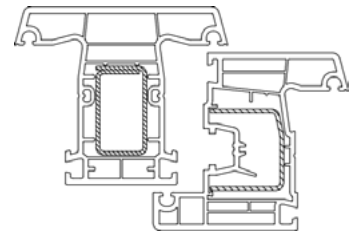

Centers	Spans for each wind zone				
	Low 510pa	Medium 680pa	High 970pa	Very High 1250pa	Extra High 1515pa
600	2820	2565	2290	2150	1975
700	2695	2450	2175	2000	1895
800	2580	2345	2100	1930	1810
900	2505	2275	2020	1875	1760
1000	2415	2220	1970	1815	1730
1100	2365	2150	1945	1790	1690
1200	2300	2130	1890	1770	1660
1300	2280	2070	1875	1730	1655
1400	2225	2060	1865	1720	1645
1500	2215	2015	1830	1720	1620
1600	2170	2015	1830	1690	1620
1700	2170	2000	1800	1690	1600
1800	2130	1990	1800	1625	1485

**14x341 with 229101
14x320 with 259026**

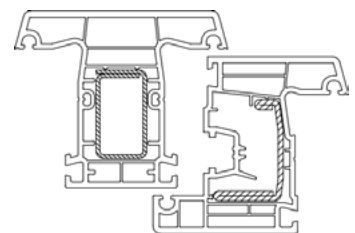

Centers	Spans for each wind zone				
	Low 510pa	Medium 680pa	High 970pa	Very High 1250pa	Extra High 1515pa
600	2860	2690	2400	2210	2045
700	2810	2570	2280	2095	1985
800	2705	2455	2205	2000	1900
900	2600	2385	2120	1970	1845
1000	2535	2305	2070	1900	1815
1100	2455	2255	2005	1875	1760
1200	2410	2190	1985	1835	1740
1300	2360	2175	1970	1785	1730
1400	2335	2135	1920	1780	1690
1500	2305	2110	1920	1760	1690
1600	2275	2110	1880	1760	1680
1700	2265	2070	1880	1760	1680
1800	2235	2065	1880	1755	1600

**14x341 with 229098
14x320 with 259026**

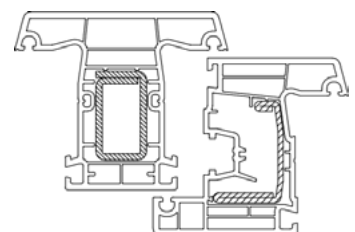

14x341 Mullion and 14x320 Tilt & Turn Sash

- ▶ This sheet is only applicable if the profile combination is continuous from head to sill and not applicable if fixed light above or below.
- ▶ Spans are the maximum calculated allowable, based on the revised NZS 4211, which requires that the member deflection at serviceability wind press (SWP) should not exceed 1/200 of the span.
- ▶ All spans have been calculated to indicate performance in each wind zone. Current NZS 4211 compliance should be checked against the latest aluplast reports and size limits imposed by NZS 4211, Section 5.2.2, should not be exceeded.
- ▶ Any custom calculations can be performed as required on request.

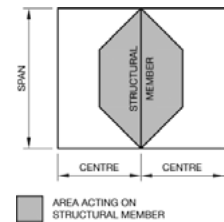

Centers	Spans for each wind zone				
	Low 510pa	Medium 680pa	High 970pa	Very High 1250pa	Extra High 1515pa
600	1935	1760	1575	1450	1360
700					
800					
900					
1000	1695	1540	1395	1310	1230
1100					
1200					
1300					
1400	1625	1475	1310	1205	1100
1500					
1600					
1700					
1800	1455	1290	1125	1035	950

14x341 with 229100

Centers	Spans for each wind zone				
	Low 510pa	Medium 680pa	High 970pa	Very High 1250pa	Extra High 1515pa
600	2455	2240	1990	1830	1715
700					
800					
900					
1000	2125	1930	1745	1605	1535
1100					
1200					
1300					
1400	1970	1830	1645	1535	1470
1500					
1600					
1700					
1800	1905	1785	1535	1375	1260

**14x341 with 229100
14x320 with 249016**

Centers	Spans for each wind zone				
	Low 510pa	Medium 680pa	High 970pa	Very High 1250pa	Extra High 1515pa
600	2730	2480	2215	2035	1910
700					
800					
900					
1000	2340	2145	1905	1785	1675
1100					
1200					
1300					
1400	2155	1995	1810	1665	1605
1500					
1600					
1700					
1800	2115	1925	1765	1570	1435

**14x341 with 229100
14x320 with 259026**

14x345 Mullion and 14x320 Tilt & Turn Sash

- ▶ This sheet is only applicable if the profile combination is continuous from head to sill and not applicable if fixed light above or below.
- ▶ Spans are the maximum calculated allowable, based on the revised NZS 4211, which requires that the member deflection at serviceability wind press (SWP) should not exceed 1/200 of the span.
- ▶ All spans have been calculated to indicate performance in each wind zone. Current NZS 4211 compliance should be checked against the latest aluplast reports and size limits imposed by NZS 4211, Section 5.2.2, should not be exceeded.
- ▶ Any custom calculations can be performed as required on request.

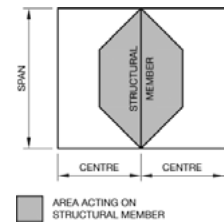

Centers	Spans for each wind zone				
	Low 510pa	Medium 680pa	High 970pa	Very High 1250pa	Extra High 1515pa
600	2860	2860	2625	2410	2215
700	2860	2805	2505	2305	2160
800	2860	2700	2400	2225	2085
900	2855	2595	2325	2140	2005
1000	2785	2545	2245	2085	1955
1100	2695	2450	2200	2020	1930
1200	2650	2405	2180	2000	1875
1300	2580	2360	2120	1985	1860
1400	2545	2330	2110	1935	1860
1500	2505	2305	2060	1935	1815
1600	2460	2270	2060	1895	1815
1700	2450	2265	2020	1895	1790
1800	2405	2230	2020	1890	1790

**14x345 with 249035
14x320 with 249016**

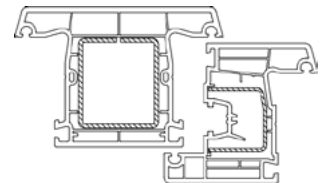

Centers	Spans for each wind zone				
	Low 510pa	Medium 680pa	High 970pa	Very High 1250pa	Extra High 1515pa
600	2860	2860	2760	2535	2390
700	2860	2860	2635	2420	2270
800	2860	2840	2520	2315	2195
900	2860	2730	2445	2250	2110
1000	2860	2660	2360	2195	2060
1100	2835	2575	2315	2125	2000
1200	2755	2530	2245	2105	1975
1300	2710	2465	2230	2050	1960
1400	2645	2460	2175	2035	1910
1500	2635	2395	2165	2000	1910
1600	2580	2385	2130	1990	1880
1700	2575	2340	2125	1990	1880
1800	2525	2340	2115	1970	1880

**14x345 with 249035
14x320 with 259026**

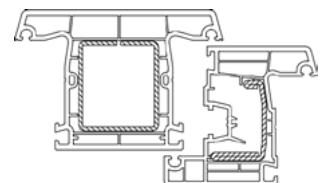

Centers	Spans for each wind zone				
	Low 510pa	Medium 680pa	High 970pa	Very High 1250pa	Extra High 1515pa
600	2860	2860	2860	2860	2860
700	2860	2860	2860	2860	2860
800	2860	2860	2860	2860	2855
900	2860	2860	2860	2860	2745
1000	2860	2860	2860	2850	2675
1100	2860	2860	2860	2760	2590
1200	2860	2860	2860	2685	2545
1300	2860	2860	2860	2640	2475
1400	2860	2860	2805	2575	2460
1500	2860	2860	2740	2565	2405
1600	2860	2860	2730	2510	2400
1700	2860	2860	2680	2505	2350
1800	2860	2860	2680	2460	2350

**12x109 with 259926
14x345 with 249035
14x320 with 259026**

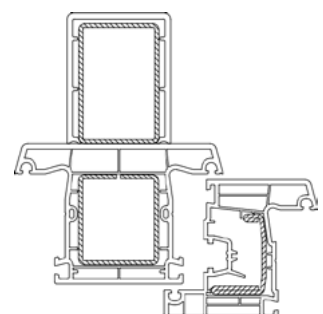

14x341 Mullion and 14x320 Tilt & Turn Sash with 12x109 Static Post

- ▶ This sheet is only applicable if the profile combination is continuous from head to sill and not applicable if fixed light above or below.
- ▶ Spans are the maximum calculated allowable, based on the revised NZS 4211, which requires that the member deflection at serviceability wind press (SWP) should not exceed 1/200 of the span.
- ▶ All spans have been calculated to indicate performance in each wind zone. Current NZS 4211 compliance should be checked against the latest aluplast reports and size limits imposed by NZS 4211, Section 5.2.2, should not be exceeded.
- ▶ Any custom calculations can be performed as required on request.

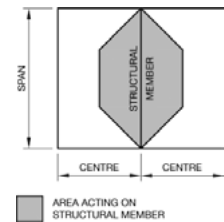

Centers	Spans for each wind zone				
	Low 510pa	Medium 680pa	High 970pa	Very High 1250pa	Extra High 1515pa
600	2860	2860	2860	2725	2555
700	2860	2860	2820	2605	2445
800	2860	2860	2725	2490	2335
900	2860	2860	2610	2420	2270
1000	2860	2855	2570	2335	2215
1100	2860	2770	2460	2285	2145
1200	2860	2690	2420	2220	2125
1300	2860	2650	2360	2205	2065
1400	2845	2585	2340	2150	2055
1500	2780	2575	2305	2140	2010
1600	2775	2520	2285	2130	2010
1700	2720	2515	2265	2100	2000
1800	2720	2470	2240	2100	1985

**12x109 with 229125
14x341 with 229101
14x320 with 249016**

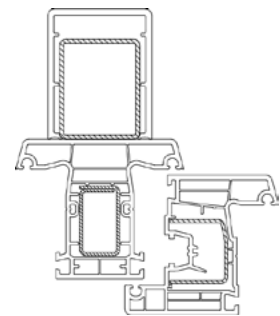

Centers	Spans for each wind zone				
	Low 510pa	Medium 680pa	High 970pa	Very High 1250pa	Extra High 1515pa
600	2860	2860	2860	2860	2705
700	2860	2860	2860	2755	2585
800	2860	2860	2860	2635	2495
900	2860	2860	2755	2555	2420
1000	2860	2860	2685	2470	2315
1100	2860	2860	2605	2420	2270
1200	2860	2845	2555	2350	2205
1300	2860	2800	2490	2330	2185
1400	2860	2760	2475	2275	2150
1500	2860	2720	2420	2265	2125
1600	2860	2665	2410	2215	2125
1700	2860	2615	2365	2210	2080
1800	2820	2610	2365	2180	2080

**12x109 with 229125
14x341 with 229098
14x320 with 259026**

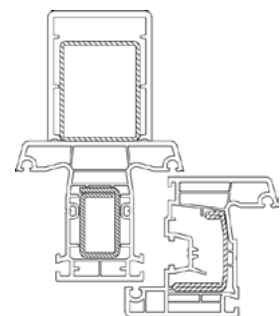

Centers	Spans for each wind zone				
	Low 510pa	Medium 680pa	High 970pa	Very High 1250pa	Extra High 1515pa
600	2860	2860	2860	2860	2860
700	2860	2860	2860	2860	2805
800	2860	2860	2860	2860	2700
900	2860	2860	2860	2765	2595
1000	2860	2860	2860	2695	2530
1100	2860	2860	2840	2610	2450
1200	2860	2860	2760	2565	2405
1300	2860	2860	2715	2495	2360
1400	2860	2860	2650	2480	2330
1500	2860	2860	2640	2425	2305
1600	2860	2860	2585	2420	2270
1700	2860	2850	2580	2370	2265
1800	2860	2795	2530	2370	2230

**12x109 with 259926
14x341 with 229098
14x320 with 259026**

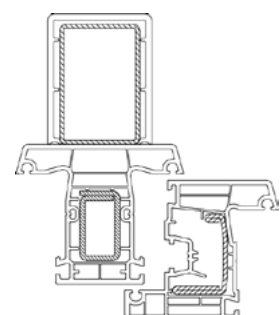

14x341 Mullion and 14x328 Door Sash

- ▶ This sheet is only applicable if the profile combination is continuous from head to sill and not applicable if fixed light above or below.
- ▶ Spans are the maximum calculated allowable, based on the revised NZS 4211, which requires that the member deflection at serviceability wind press (SWP) should not exceed 1/200 of the span.
- ▶ All spans have been calculated to indicate performance in each wind zone. Current NZS 4211 compliance should be checked against the latest aluplast reports and size limits imposed by NZS 4211, Section 5.2.2, should not be exceeded.
- ▶ Any custom calculations can be performed as required on request.

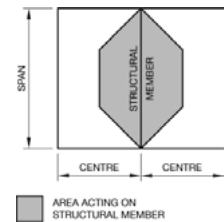

Centers	Spans for each wind zone				
	Low 510pa	Medium 680pa	High 970pa	Very High 1250pa	Extra High 1515pa
600	2860	2825	2510	2320	2175
700	2860	2700	2395	2205	2065
800	2840	2580	2295	2125	1995
900	2730	2505	2225	2045	1940
1000	2660	2420	2170	1995	1870
1100	2580	2370	2105	1970	1845
1200	2530	2300	2080	1915	1830
1300	2465	2285	2025	1900	1780
1400	2450	2225	2015	1865	1775
1500	2395	2220	2000	1850	1760
1600	2390	2170	1970	1850	1745
1700	2340	2170	1970	1825	1745
1800	2340	2135	1950	1825	1730

**14x328 with 209193
14x341 with 229101**

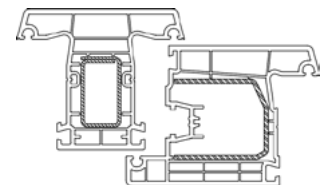

Centers	Spans for each wind zone				
	Low 510pa	Medium 680pa	High 970pa	Very High 1250pa	Extra High 1515pa
600	2860	2860	2600	2400	2255
700	2860	2800	2485	2285	2140
800	2860	2675	2375	2205	2070
900	2835	2575	2305	2120	2000
1000	2760	2510	2230	2070	1940
1100	2675	2440	2180	2005	1915
1200	2625	2385	2160	1985	1860
1300	2555	2360	2100	1970	1845
1400	2540	2310	2090	1920	1840
1500	2485	2300	2045	1920	1800
1600	2460	2250	2045	1880	1800
1700	2430	2250	2005	1880	1785
1800	2400	2215	2005	1880	1785

**14x328 with 209193
14x341 with 229098**

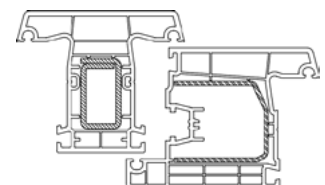

Centers	Spans for each wind zone				
	Low 510pa	Medium 680pa	High 970pa	Very High 1250pa	Extra High 1515pa
600	2860	2860	2840	2610	2415
700	2860	2860	2715	2495	2340
800	2860	2860	2595	2385	2225
900	2860	2810	2520	2315	2170
1000	2860	2740	2430	2235	2120
1100	2860	2655	2380	2190	2055
1200	2835	2605	2315	2165	2030
1300	2790	2535	2295	2110	2000
1400	2725	2520	2240	2100	1965
1500	2675	2465	2230	2050	1965
1600	2620	2425	2185	2050	1925
1700	2615	2410	2155	2010	1925
1800	2600	2400	2145	2010	1900

**14x328 with 209193
14x341 with 229098
and 2x 259023**

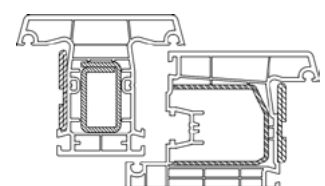

14x345 Mullion and 14x328 Door Sash

- ▶ This sheet is only applicable if the profile combination is continuous from head to sill and not applicable if fixed light above or below.
- ▶ Spans are the maximum calculated allowable, based on the revised NZS 4211, which requires that the member deflection at serviceability wind press (SWP) should not exceed 1/200 of the span.
- ▶ All spans have been calculated to indicate performance in each wind zone. Current NZS 4211 compliance should be checked against the latest aluplast reports and size limits imposed by NZS 4211, Section 5.2.2, should not be exceeded.
- ▶ Any custom calculations can be performed as required on request.

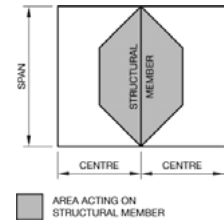

Centers	Spans for each wind zone				
	Low 510pa	Medium 680pa	High 970pa	Very High 1250pa	Extra High 1515pa
600	2860	2860	2860	2685	2520
700	2860	2860	2795	2565	2410
800	2860	2860	2670	2455	2305
900	2860	2860	2570	2385	2235
1000	2860	2820	2505	2300	2180
1100	2860	2730	2440	2255	2115
1200	2860	2665	2380	2190	2090
1300	2860	2610	2360	2170	2035
1400	2805	2545	2305	2150	2025
1500	2740	2535	2295	2110	2000
1600	2735	2485	2250	2110	1980
1700	2680	2480	2250	2070	1980
1800	2680	2435	2210	2070	1955

14x328 with 209193
14x345 with 249035

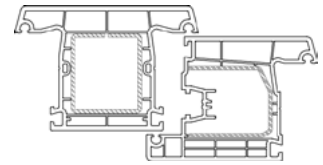

Centers	Spans for each wind zone				
	Low 510pa	Medium 680pa	High 970pa	Very High 1250pa	Extra High 1515pa
600	2860	2860	2860	2860	2860
700	2860	2860	2860	2860	2850
800	2860	2860	2860	2860	2745
900	2860	2860	2860	2815	2640
1000	2860	2860	2860	2740	2570
1100	2860	2860	2860	2655	2490
1200	2860	2860	2805	2610	2445
1300	2860	2860	2765	2540	2380
1400	2860	2860	2695	2525	2365
1500	2860	2860	2685	2465	2315
1600	2860	2860	2625	2460	2310
1700	2860	2860	2615	2410	2265
1800	2860	2845	2575	2400	2265

12x109 with 229125
14x328 with 209193
14x345 with 249035

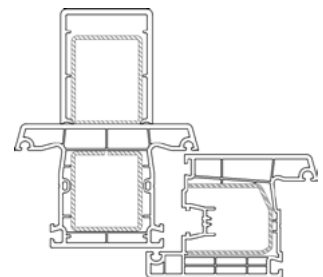

Centers	Spans for each wind zone				
	Low 510pa	Medium 680pa	High 970pa	Very High 1250pa	Extra High 1515pa
600	2860	2860	2860	2860	2860
700	2860	2860	2860	2860	2860
800	2860	2860	2860	2860	2860
900	2860	2860	2860	2860	2820
1000	2860	2860	2860	2860	2745
1100	2860	2860	2860	2835	2660
1200	2860	2860	2860	2755	2615
1300	2860	2860	2860	2715	2545
1400	2860	2860	2860	2645	2530
1500	2860	2860	2815	2635	2470
1600	2860	2860	2805	2580	2460
1700	2860	2860	2750	2575	2415
1800	2860	2860	2750	2530	2400

12x109 with 259926
14x328 with 209193
14x345 with 249035

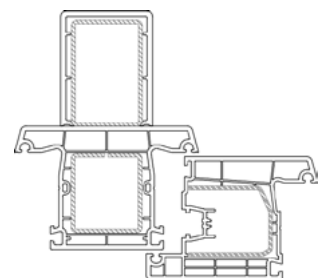

14x341 Mullion and 14x328 Door Sash with 12x109 Static Post

- ▶ This sheet is only applicable if the profile combination is continuous from head to sill and not applicable if fixed light above or below.
- ▶ Spans are the maximum calculated allowable, based on the revised NZS 4211, which requires that the member deflection at serviceability wind press (SWP) should not exceed 1/200 of the span.
- ▶ All spans have been calculated to indicate performance in each wind zone. Current NZS 4211 compliance should be checked against the latest aluplast reports and size limits imposed by NZS 4211, Section 5.2.2, should not be exceeded.
- ▶ Any custom calculations can be performed as required on request.

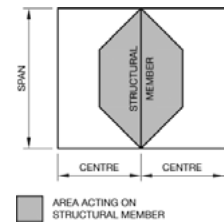

Centers	Spans for each wind zone				
	Low 510pa	Medium 680pa	High 970pa	Very High 1250pa	Extra High 1515pa
600	2860	2860	2860	2860	2765
700	2860	2860	2860	2800	2645
800	2860	2860	2860	2695	2530
900	2860	2860	2820	2590	2455
1000	2860	2860	2750	2525	2370
1100	2860	2860	2660	2445	2320
1200	2860	2860	2615	2400	2255
1300	2860	2860	2545	2360	2235
1400	2860	2795	2530	2325	2180
1500	2860	2730	2475	2305	2170
1600	2860	2725	2460	2265	2130
1700	2860	2670	2420	2265	2130
1800	2860	2670	2400	2230	2115

Centers	Spans for each wind zone				
	Low 510pa	Medium 680pa	High 970pa	Very High 1250pa	Extra High 1515pa
600	2860	2860	2860	2860	2860
700	2860	2860	2860	2860	2855
800	2860	2860	2860	2860	2745
900	2860	2860	2860	2815	2640
1000	2860	2860	2860	2745	2575
1100	2860	2860	2860	2655	2490
1200	2860	2860	2810	2610	2445
1300	2860	2860	2765	2540	2385
1400	2860	2860	2695	2525	2370
1500	2860	2860	2685	2470	2315
1600	2860	2860	2630	2460	2310
1700	2860	2860	2615	2415	2265
1800	2860	2845	2575	2400	2265

Centers	Spans for each wind zone				
	Low 510pa	Medium 680pa	High 970pa	Very High 1250pa	Extra High 1515pa
600	2860	2860	2860	2860	2860
700	2860	2860	2860	2860	2860
800	2860	2860	2860	2860	2860
900	2860	2860	2860	2860	2780
1000	2860	2860	2860	2860	2710
1100	2860	2860	2860	2800	2625
1200	2860	2860	2860	2720	2575
1300	2860	2860	2860	2675	2510
1400	2860	2860	2845	2610	2495
1500	2860	2860	2775	2600	2440
1600	2860	2860	2770	2545	2430
1700	2860	2860	2715	2540	2385
1800	2860	2860	2715	2495	2385

12x109 with 229125
14x328 with 209193
14x341 with 229101

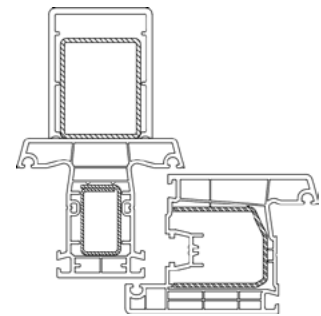

12x109 with 259926
14x328 with 209193
14x341 with 229101

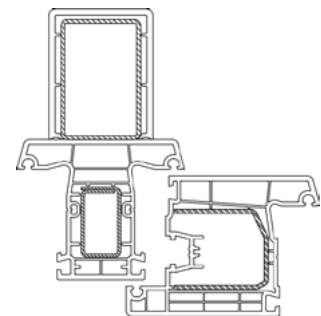

12x109 with 259926
14x328 with 209193
14x341 with 229098

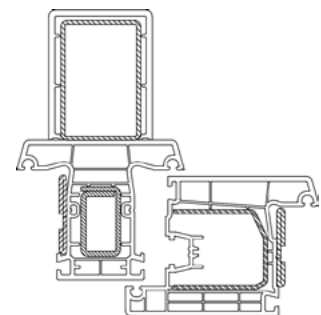

2x 14x328 Door Sash with 14x366 Mullion

- ▶ Spans are the maximum calculated allowable, based on the revised NZS 4211, which requires that the member deflection at serviceability wind press (SWP) should not exceed 1/200 of the span.
- ▶ All spans have been calculated to indicate performance in each wind zone. Current NZS 4211 compliance should be checked against the latest aluplast reports and size limits imposed by NZS 4211, Section 5.2.2, should not be exceeded.
- ▶ Any custom calculations can be performed as required on request.

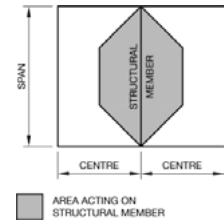

Centers	Spans for each wind zone				
	Low 510pa	Medium 680pa	High 970pa	Very High 1250pa	Extra High 1515pa
700	2860	2860	2860	2685	2520
800	2860	2860	2795	2570	2410
900	2860	2860	2685	2490	2340
1000	2860	2860	2620	2405	2255
1100	2860	2855	2535	2355	2210
1200	2860	2775	2490	2290	2180
1300	2860	2730	2425	2270	2130

**2 x 14x328 with 209193
14x366 with 229063**

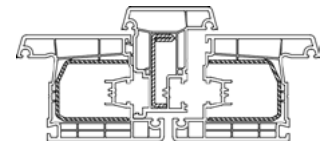

Centers	Spans for each wind zone				
	Low 510pa	Medium 680pa	High 970pa	Very High 1250pa	Extra High 1515pa
700	2860	2860	2860	2825	2665
800	2860	2860	2860	2720	2550
900	2860	2860	2845	2615	2475
1000	2860	2860	2770	2545	2390
1100	2860	2860	2685	2465	2340
1200	2860	2860	2635	2425	2270
1300	2860	2860	2565	2360	2255

**2 x 14x328 with 209193 and
2x 259023 14x366 with 229063**

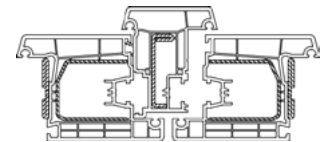

Coupled 14x307 Options

- ▶ Spans are the maximum calculated allowable, based on the revised NZS 4211, which requires that the member deflection at serviceability wind press (SWP) should not exceed 1/200 of the span.
- ▶ All spans have been calculated to indicate performance in each wind zone. Current NZS 4211 compliance should be checked against the latest aluplast reports and size limits imposed by NZS 4211, Section 5.2.2, should not be exceeded.
- ▶ Any custom calculations can be performed as required on request.

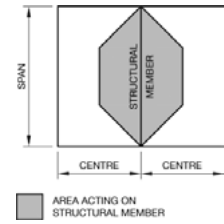

2 × 14×307 with 259106 14×267 with 2× 209900

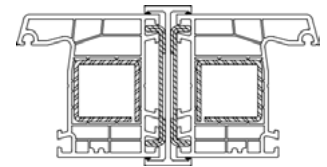

2 × 14×307 with 259106 14×218 with 289218

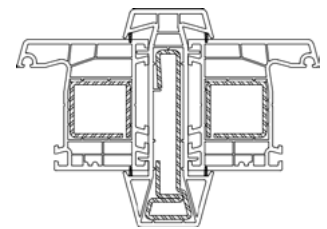

2 × 14×307 with 259106 14×218 with 289218 and 70mm x 6mm flat bar

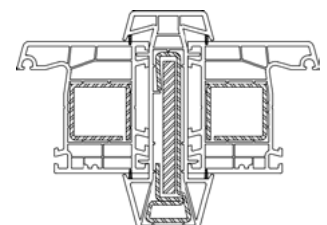

Centers	Spans for each wind zone				
	Low 510pa	Medium 680pa	High 970pa	Very High 1250pa	Extra High 1515pa
600	2860	2860	2860	2860	2690
700	2860	2860	2860	2745	2570
800	2860	2860	2855	2625	2460
900	2860	2860	2745	2545	2390
1000	2860	2860	2675	2460	2305
1100	2860	2860	2590	2410	2255
1200	2860	2835	2545	2340	2195
1300	2860	2790	2475	2320	2175
1400	2860	2720	2465	2265	2150
1500	2860	2710	2405	2255	2115
1600	2860	2650	2400	2205	2115
1700	2860	2615	2355	2205	2075
1800	2805	2600	2355	2170	2075

Centers	Spans for each wind zone				
	Low 510pa	Medium 680pa	High 970pa	Very High 1250pa	Extra High 1515pa
600	2860	2860	2860	2860	2860
700	2860	2860	2860	2860	2860
800	2860	2860	2860	2860	2860
900	2860	2860	2860	2860	2860
1000	2860	2860	2860	2860	2860
1100	2860	2860	2860	2860	2860
1200	2860	2860	2860	2860	2785
1300	2860	2860	2860	2860	2740
1400	2860	2860	2860	2850	2675
1500	2860	2860	2860	2785	2670
1600	2860	2860	2860	2775	2605
1700	2860	2860	2860	2720	2600
1800	2860	2860	2860	2720	2555

Centers	Spans for each wind zone				
	Low 510pa	Medium 680pa	High 970pa	Very High 1250pa	Extra High 1515pa
600	2860	2860	2860	2860	2860
700	2860	2860	2860	2860	2860
800	2860	2860	2860	2860	2860
900	2860	2860	2860	2860	2860
1000	2860	2860	2860	2860	2860
1100	2860	2860	2860	2860	2860
1200	2860	2860	2860	2860	2860
1300	2860	2860	2860	2860	2860
1400	2860	2860	2860	2860	2860
1500	2860	2860	2860	2860	2860
1600	2860	2860	2860	2860	2860
1700	2860	2860	2860	2860	2835
1800	2860	2860	2860	2860	2785



Smart-slide - Scheme A

- ▶ Spans are the maximum calculated allowable, based on the revised NZS4211:2008, which requires that the member deflection at serviceability wind press (SWP) should not exceed 1/200 of the span.
- ▶ 2640mm is the maximum over frame height limit and 1575mm is the maximum allowable opening size from edge of frame to centre of mullion, as per the Roto Patio Inowa Order Document.

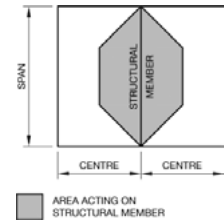

Spans for each wind zone					
Centers	Low	Medium	High	Very High	Extra High
800	2640	2640	2640	2540	2380
900	2640	2640	2640	2460	2310
1000	2640	2640	2585	2375	2230
1100	2640	2640	2505	2325	2180
1200	2640	2640	2460	2260	2160
1300	2640	2640	2395	2240	2105
1400	2640	2640	2380	2190	2090
1500	2640	2620	2325	2180	2045
1600	2640	2565	2325	2135	2045
1700	2640	2565	2275	2135	2005
1800	2640	2515	2275	2135	2005
1900	2640	2515	2240	2115	2000
2000	2640	2515	2240	2080	2000

aluplast smart-slide
209294, 249035

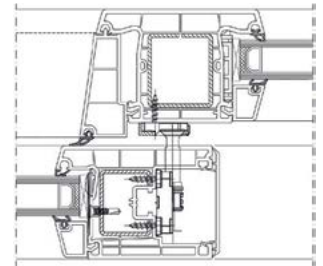

Spans for each wind zone					
Centers	Low	Medium	High	Very High	Extra High
800	2640	2640	2640	2640	2640
900	2640	2640	2640	2640	2640
1000	2640	2640	2640	2640	2570
1100	2640	2640	2640	2640	2490
1200	2640	2640	2640	2605	2445
1300	2640	2640	2640	2540	2380
1400	2640	2640	2640	2520	2365
1500	2640	2640	2640	2465	2310
1600	2640	2640	2625	2460	2310
1700	2640	2640	2615	2410	2265
1800	2640	2640	2575	2400	2270
1900	2640	2640	2530	2375	2235
2000	2640	2640	2530	2350	2235

aluplast smart-slide with static
post 209294, 249035, 229125

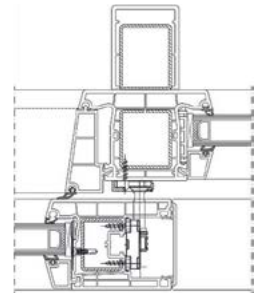

Spans for each wind zone					
Centers	Low	Medium	High	Very High	Extra High
800	2640	2640	2640	2640	2640
900	2640	2640	2640	2640	2640
1000	2640	2640	2640	2640	2640
1100	2640	2640	2640	2640	2580
1200	2640	2640	2640	2640	2530
1300	2640	2640	2640	2630	2465
1400	2640	2640	2640	2565	2450
1500	2640	2640	2640	2555	2395
1600	2640	2640	2640	2500	2390
1700	2640	2640	2640	2500	2345
1800	2640	2640	2640	2450	2345
1900	2640	2640	2620	2450	2305
2000	2640	2640	2620	2420	2305

aluplast smart-slide with static
post 209294, 249035, 259926

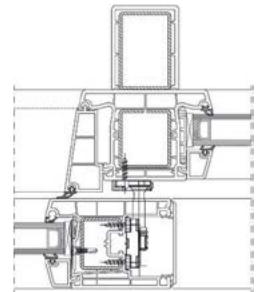

CARE & MAINTENANCE

Cleaning

STARKE AMBIANCE window profiles are made of a weather resistant and easy-to-care synthetic material of stable value. To clean the even, non-porous and hygienic surface, normal soapy water can be used. Soiling due to dust and rain can be removed easily by this means. Do not use abrasives or chemicals as nitro diluents, benzene or similar agents for cleaning. In case of soiling that cannot be removed as described above, please consult your window specialist.

Initial Cleaning

Despite all the care taken by the craftsmen during installation, soiling like residues of mortar, wallpaper paste, adhesives etc. may occur. Residues of mortar and colour splatters can be removed with a semi-rigid putty knife by carefully scraping off the soiling. After that, wipe with a damp cloth. Please be careful not to scratch the surfaces with the small but sharp pebbles in the mortar. Residual adhesives on the glass surface can be removed carefully with an inclined razor blade.

Maintenance

In order to ensure proper functioning of the hardware for your new STARKE AMBIANCE window and doors for years to come, the following maintenance works should be done at least once a year:

- ▶ Check all hardware elements with security-related function frequently for wear.
- ▶ Lubricate all movable parts with a drop of oil and the locking points of the hardware elements with acid-free grease or industrial Vaseline.
- ▶ Use only cleansing agents and care products that do not affect the hardware's corrosion protection.

Ventilation & Condensation

Condensation should not occur on your new STARKE AMBIANCE windows or doors. If condensation occurs, this is a sign that the humidity in your room is too high. Windows present such a high air impermeability and are sealed so tightly to the building structure that no natural air change can take place. By proper ventilation and with modern windows you can save heating costs and create a healthy room climate at the same time. Cross ventilation through two opposite windows is especially quick and effective – one single open window sometimes is not enough. Keeping the window open for 5 minutes is sufficient to change the indoor air. For a more thorough airing of the rooms, open the windows wide for 10 minutes. To facilitate the air change, Basic Air plus® or REGEL-air® ventilation systems can be installed in the window.

For this reason we recommend:

- ▶ Ventilate three to four times a day.
- ▶ Remove items that obstruct the air flow: leave an air gap between furniture and the wall; curtains should not cover the heater but reach only to the window sill.
- ▶ Keep doors to less heated rooms closed.
- ▶ Ventilate more frequently in case of additional humidity due to cooking, bathing, taking a shower etc.
- ▶ In the winter season, open your windows wide several times a day for a short time instead of keeping them tilted for hours.
- ▶ Always let humid air escape to the outside – never to other rooms.
- ▶ Fogged-up windows are a clear signal that ventilation is needed.
- ▶ Heating and frequent ventilation are the prerequisites for a healthy room climate.



WARRANTY

Starke Group Ltd warrants that, for a period of ten years from the date of supply:

- (a) NZS 4211:2008 Performance of Windows, and NZS 4223:2016 Code of Practice for Glazing in Buildings
- (b) As required under NZS 4211 the product or products specified will remain watertight.
- (c) Installation of joinery is covered the installer.

If the Product does not perform as warranted, Starke Group Ltd will make good the Product, subject to the following terms:

- (a) that the details on this coupon are filled out and returned to Starke Group Ltd within 90 days;
- (b) that Starke Group Ltd is advised of and given an opportunity to inspect any fault;
- (c) that any claims under this warranty need to be made in writing to Starke Group Ltd within 7 days of the fault first becoming apparent;
- (d) that this warranty is not transferable and only applies to the original purchaser, unless Starke Group Ltd agrees otherwise;
- (e) that this warranty only applies:
 - (a) that Starke Group Ltd will not be liable for any consequential, indirect or special damage or loss including, without limitation, any loss of profits;
 - (b) that the warranty does not apply to any fault caused by incorrect installation by anyone other than Starke Group Ltd or its authorised agents. Correct installation details are available on request.
 - (i) where the Product has been maintained in accordance with the maintenance procedure specified in this "Care and Maintenance" booklet;

- (ii) to a defect in the workmanship or a defect that is directly attributable to a defect in the material of the Product; and
- (iii) where the purchaser has paid in full for the supply (and installation if applicable) of the window joinery;
- (f) that the warranty does not apply to any:
 - (i) glass or glazing materials used in the joinery; glass breakage and surface defects except premature IGU failure as determined by Starke Group Ltd.
 - (ii) defects due to any cause beyond Starke Group Ltd.'s control including, without limitation, defects in the structure to which the joinery has been affixed;
 - (iii) materials, hardware or componentry or any joinery not manufactured by Starke Group Ltd;
 - (iv) This warranty does not apply to used or second-hand joinery
 - (v) weather tightness - where the contract is one of manufacture and supply only, the junction between joinery and cladding systems is the responsibility of the builder;
 - (a) that Starke Group Ltd will not be liable for any consequential, indirect or special damage or loss including, without limitation, any loss of profits;
 - (b) that the warranty does not apply to any fault caused by incorrect installation by anyone other than Starke Group Ltd or its authorised agents. Correct installation details are available on request.

Please note: This warranty is subject to correct installation as outlined in our Installation Details Manual. This document is available on request for you or your builder.

BRANZ Appraisal



BRANZ Appraised

Appraisal No. 1005 [2018]

ALUPLAST® UPVC WINDOWS AND DOORS

Appraisal No. 1005 (2018)

Amended 16 August 2019

BRANZ Appraisals

Technical Assessments of
products for building and
construction.



aluplast® GmbH

Auf der Breit 2
D-76227
Karlsruhe
Germany

Email: sales.international@aluplast.net

Web: www.aluplast.net



BRANZ

1222 Moonshine Rd,
RD1, Porirua 5381
Private Bag 50 908
Porirua 5240.



Scan the QR code to view
the full BRANZ report





Starke Group Ltd

2-4 Wilco Place, Wiri
Auckland 2104
New Zealand

+64 9 279 8617
sales@starke.co.nz

starke.co.nz



Looking after our planet is the only option

It's reassuring to know that our windows contribute to creating a brighter tomorrow for future generations.

Not only do we use recyclable materials wherever possible, the best bit is our high-performance windows outperform traditional windows by 48%* helping to reduce energy consumption. STÄRKE is ISO 14064-1:2018 environmentally certified with a goal of being carbon neutral by 2025.