

GREEN LIFE

WINDOWS + DOORS

ONE-STOP SOLUTIONS FOR
YOUR WINDOWS AND DOORS



Greenlifewindows.com.au

Greenlifewindows.com.au

7 year
WARRANTY



GREEN LIFE

• ABOUT US >>>



GREENS INDUSTRIAL PARK , CHINA



GREEN LIFE
WINDOWS + DOORS

Green Life Window and Door Systems have been successfully servicing the building and construction industry since 2008. Decades of experience means that this proud Australian owned and operated organization provides first class windows for residential and commercial developments across Australia. Green Life Windows has branches in Melbourne, Sydney, and Adelaide.

Our aim is to provide the clients with typical Australian window and door systems by manufacturing overseas, offering competitive price, high quality products, while providing timely service as the local manufacturer.



AWNING WINDOW GL 70 SERIES THERMAL BREAK

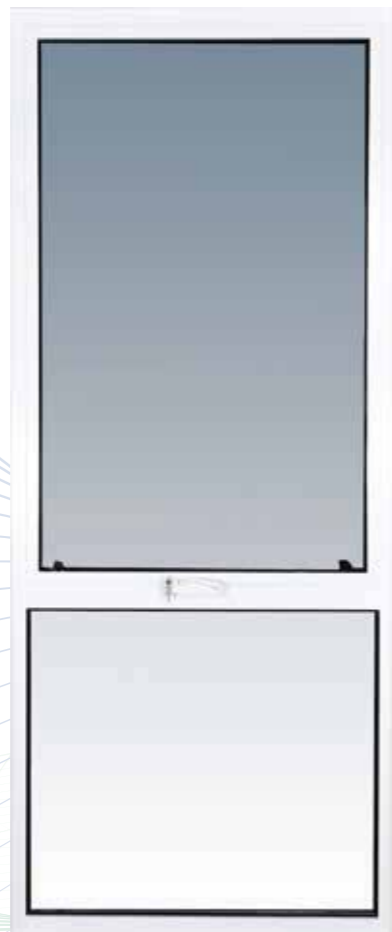

This architectural design window with slim line of 44mm width and 70 mm depth of frame, mullion and transom with 1.8 mm internal radius. Square external glazing beads are standard. The extra strong sash allows large sash windows to be fabricated for high wind load areas. The system has been tested for compliance with the relevant Australian standards, achieving very high ultimate strength of 3300 Pa and water resistance of 300 Pa and low air infiltration. Design with magnetic style stainless steel screen mesh and stainless steel linkage winder with keyed. It can be paired with Crimsafe heavy duty/fire rate screening system.

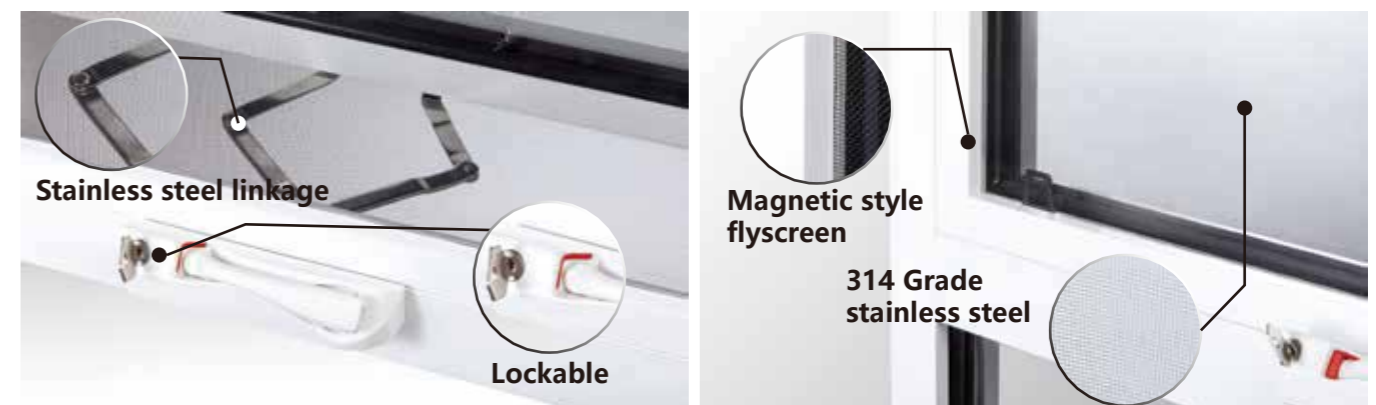
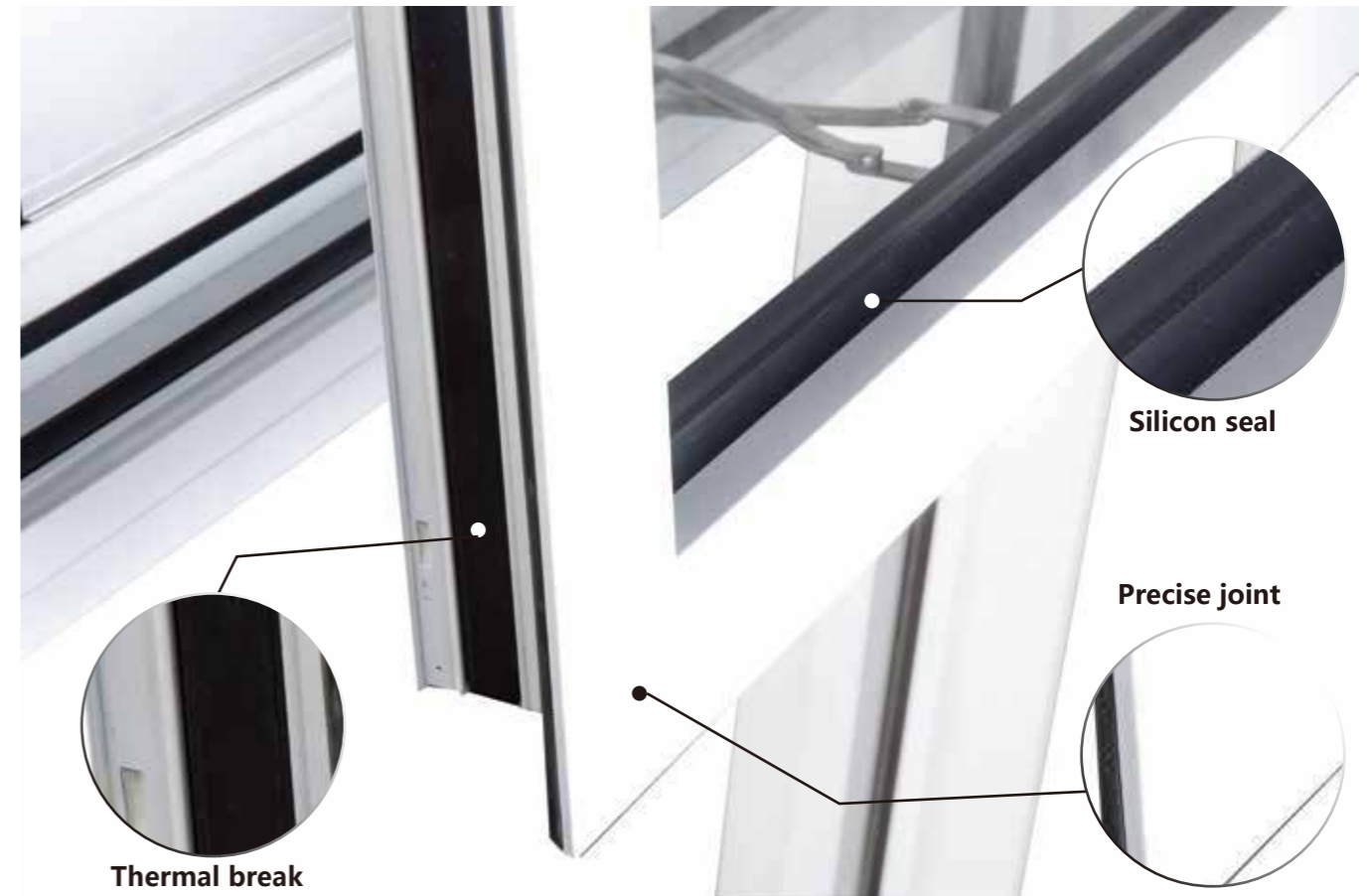

AWNING WINDOW GL 100 SERIES NON-THERMAL BREAK



Inspired by commercial grade awning window systems, the commercial grade window system has been tested for compliance with the relevant Australian standards, achieving very high ultimate strength of 3300 Pa and water resistance of 300 Pa and low air infiltration, incorporates commercial design features, these elegant awning and casement windows can withstand the harshest of environments and keep you safe from the elements. Awning sashes can be fitted with cam handles, manual chain winders or concealed electric winders. Awning sashes can be fitted with side lock and linkage winder. Intergraded with stainless steel screen mesh. It can be paired with the Crimsafe heavy duty/fire rate screening system.

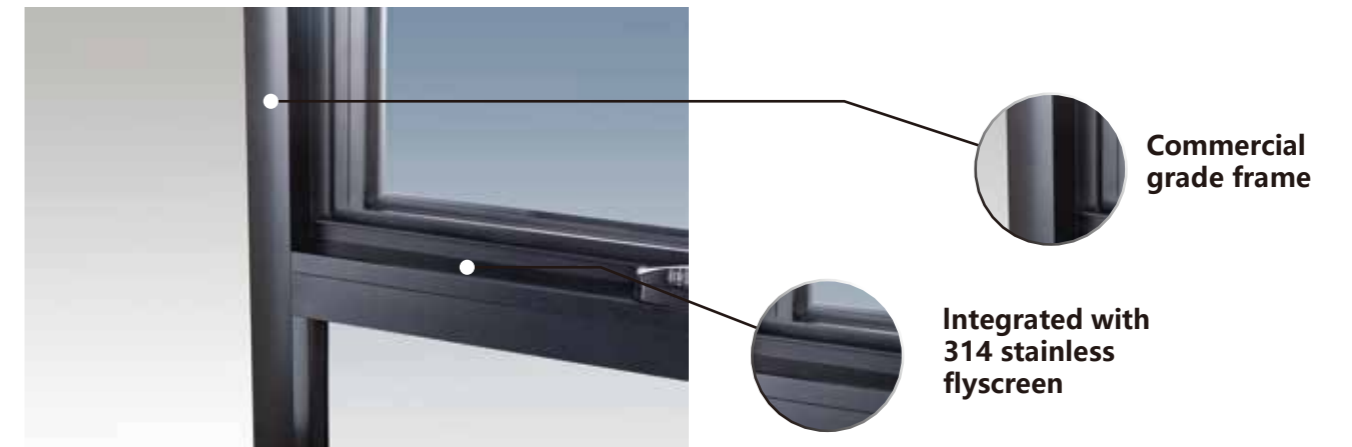
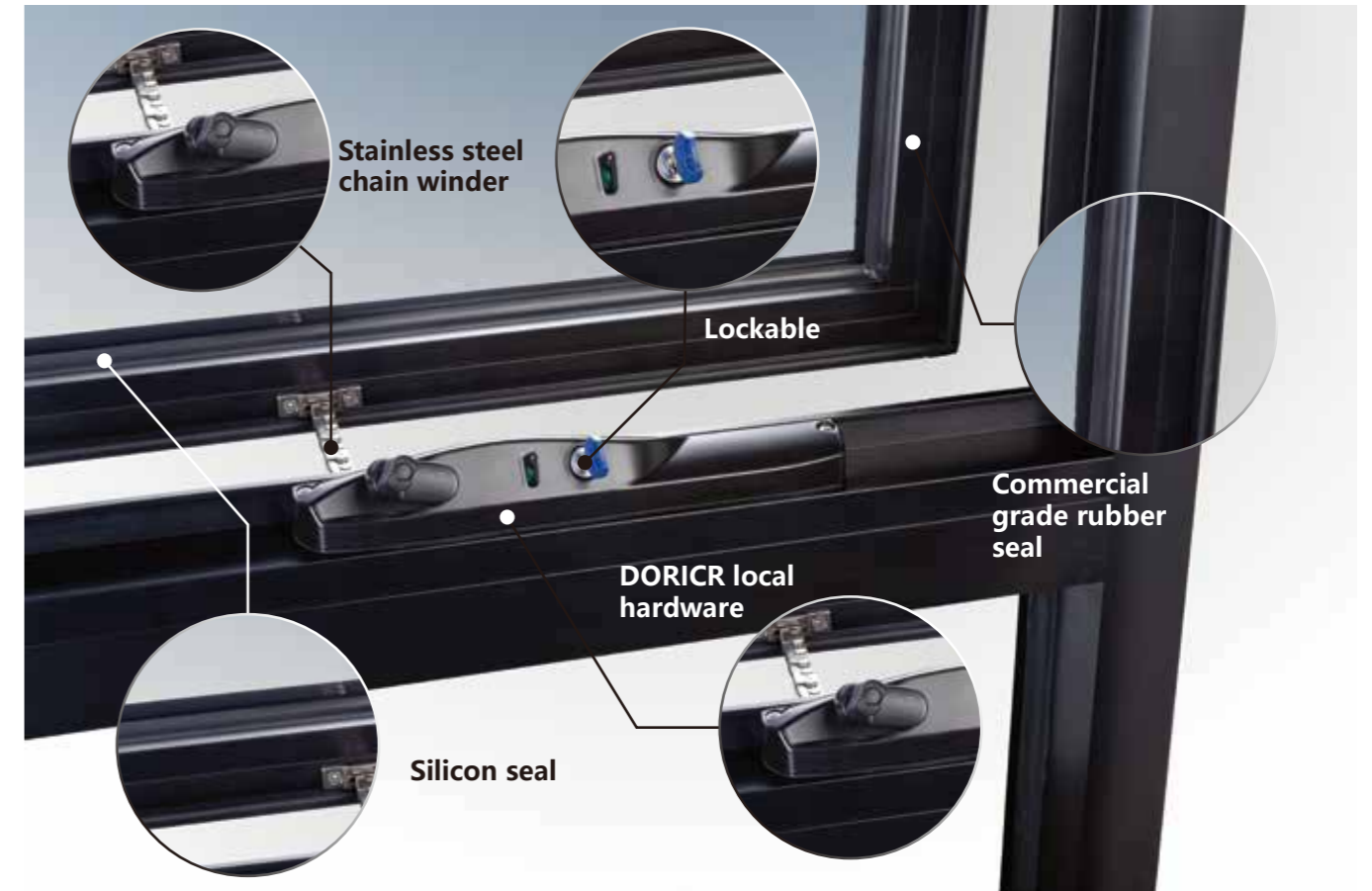

CASEMENT WINDOW

GL 100 SERIES

NON-THERMAL BREAK



Inspired by commercial grade awning window systems, the commercial grade window system has been tested for compliance with the relevant Australian standards, achieving very high ultimate strength of 3300 Pa and water resistance of 300 Pa and low air infiltration, incorporates commercial design features, these elegant awning and casement windows can withstand the harshest of environments and keep you safe from the elements. Awning sashes can be fitted with cam handles, manual chain winders or concealed electric winders. Awning sashes can be fitted with side lock and linkage winder. Intergrated with stainless steel screen mesh. It can be paired with the Crimsafe heavy duty/fire rate screening system.

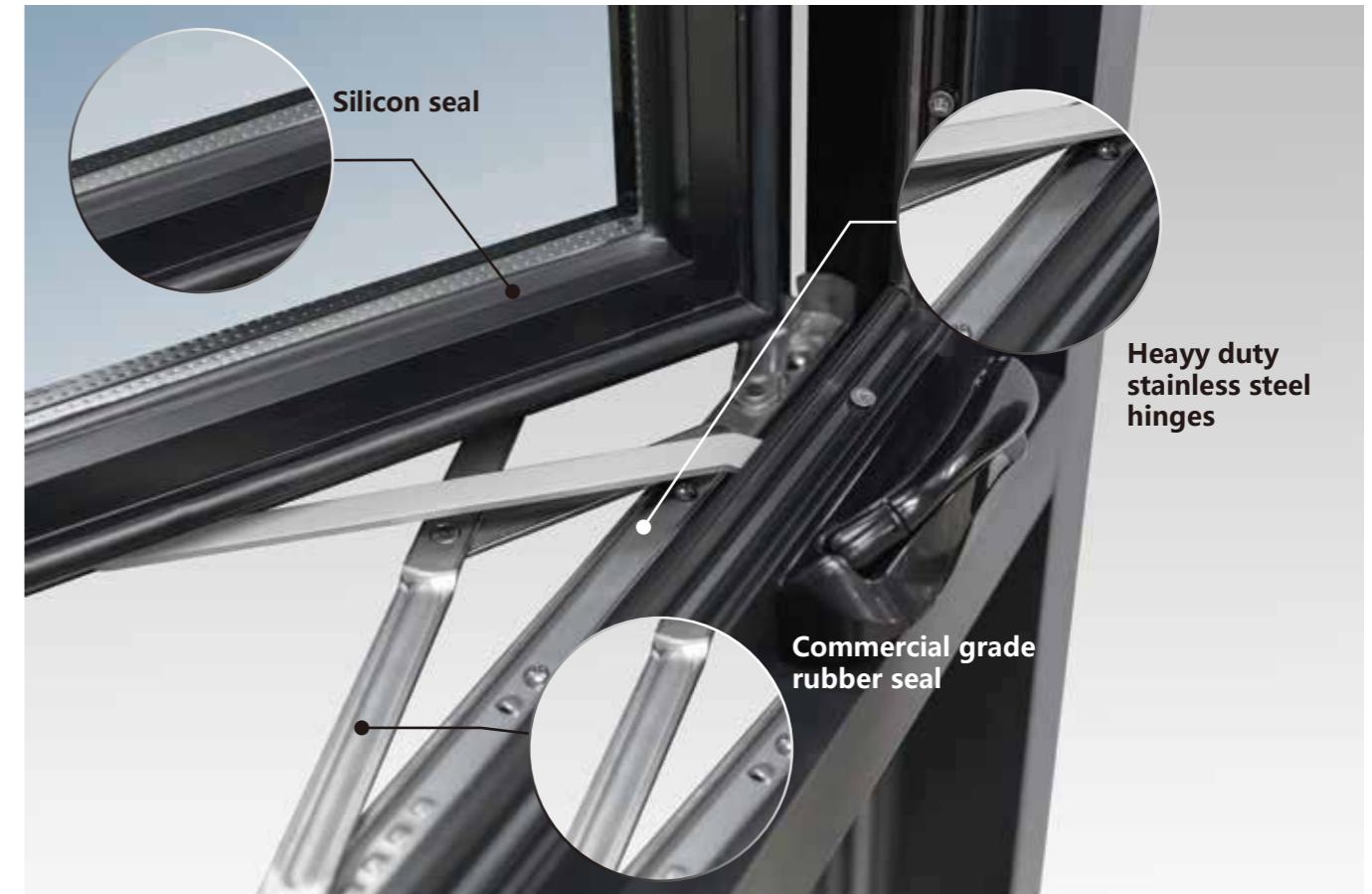

SLIDING WINDOW

GL 100 SERIES

NON-THERMAL/ THERMAL BREAK



Inspired by architectural design sliding door systems, the non-thermal and thermal break Sliding window incorporates slim design features within a platform purposely designed for modern residential applications. Intergrated with stainless steel track, nylon heavy duty runner and heavy duty mesh screen and Doric recessed lock for smooth, quiet operation and your home security. The system has been tested for compliance with the relevant Australian standards, achieving very high ultimate strength of 3300 Pa and water resistance of 300 Pa and low air infiltration. It can be paired with the Crimsafe heavy duty/fire rate screening system.

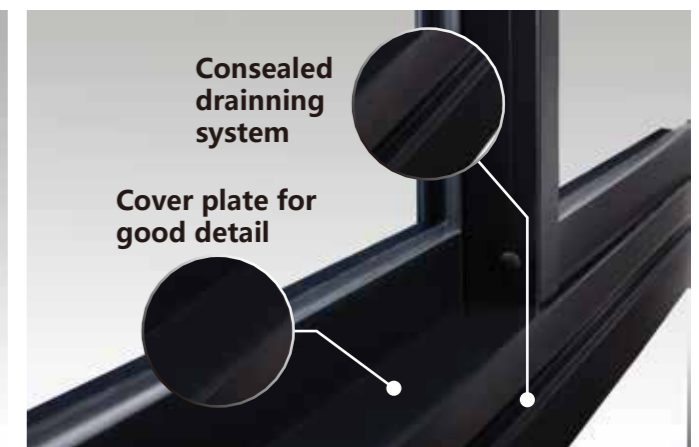
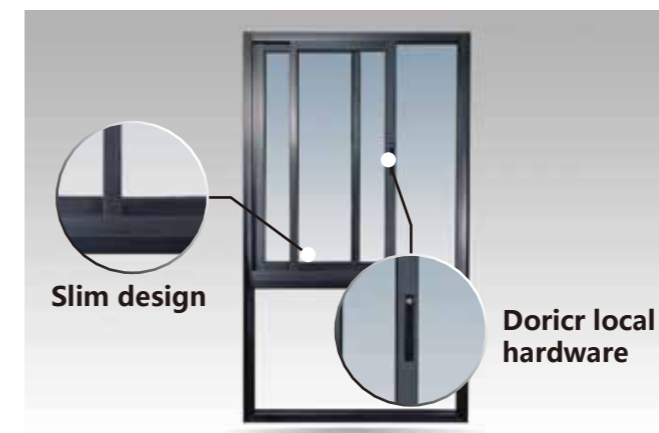
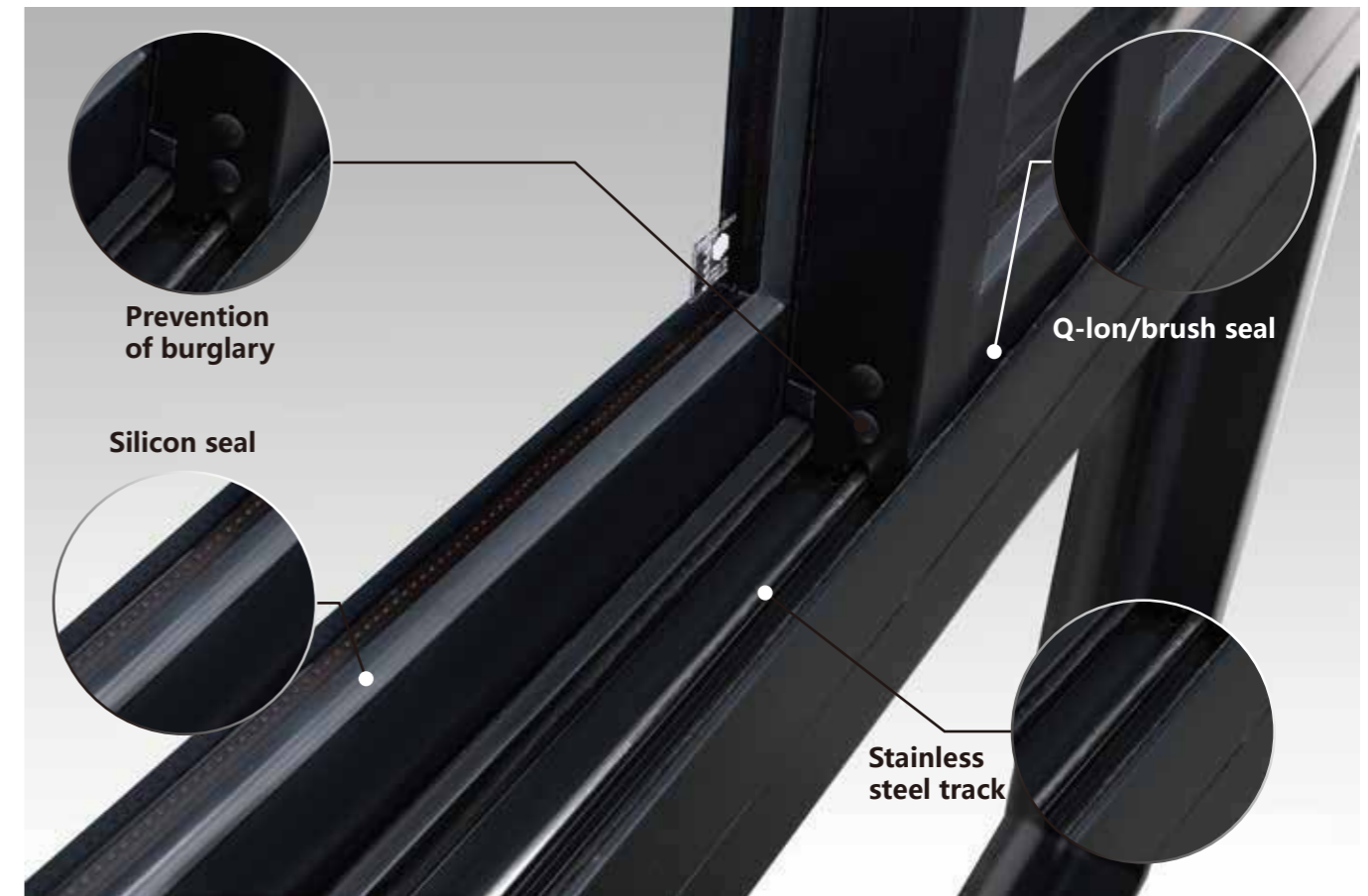

SLIDING DOOR

GL 100/150/200/250 SERIES

THERMAL BREAK

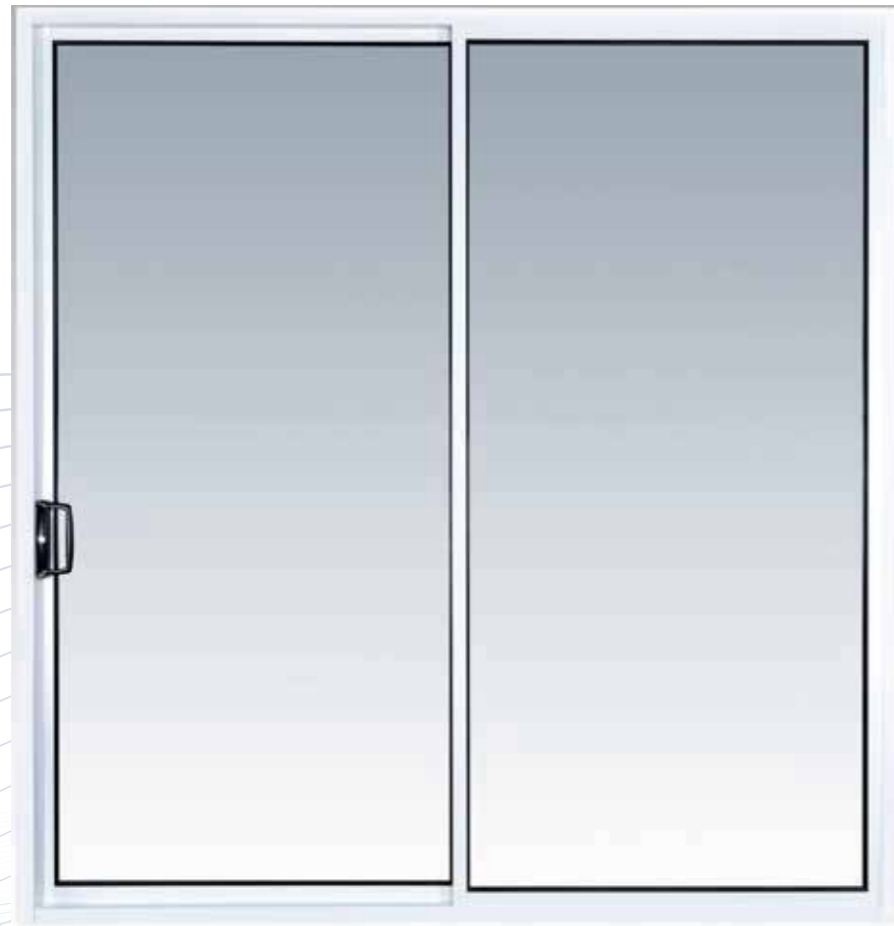

Inspired by architectural design sliding door systems, the thermal break Sliding Door incorporates slim design features within a platform purposely designed for modern residential applications. Intergraded with stainless steel track, nylon heavy duty runner and heavy duty mesh screen for smooth, quiet operation and your home security. The Series is a bold and unique system with up to five sliding panels in each direction. The system has been tested for compliance with the relevant Australian standards, achieving very high ultimate strength of 3300 Pa and water resistance of 300 Pa and low air infiltration. It can be paired with the Brio 612 retractable and Crimsafe heavy duty/fire rate screening system.

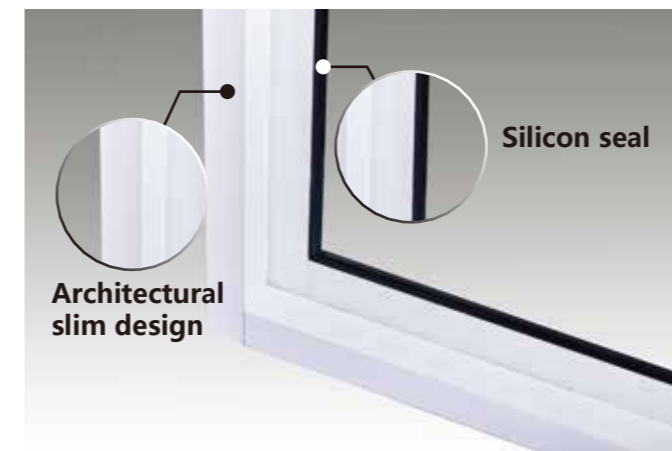
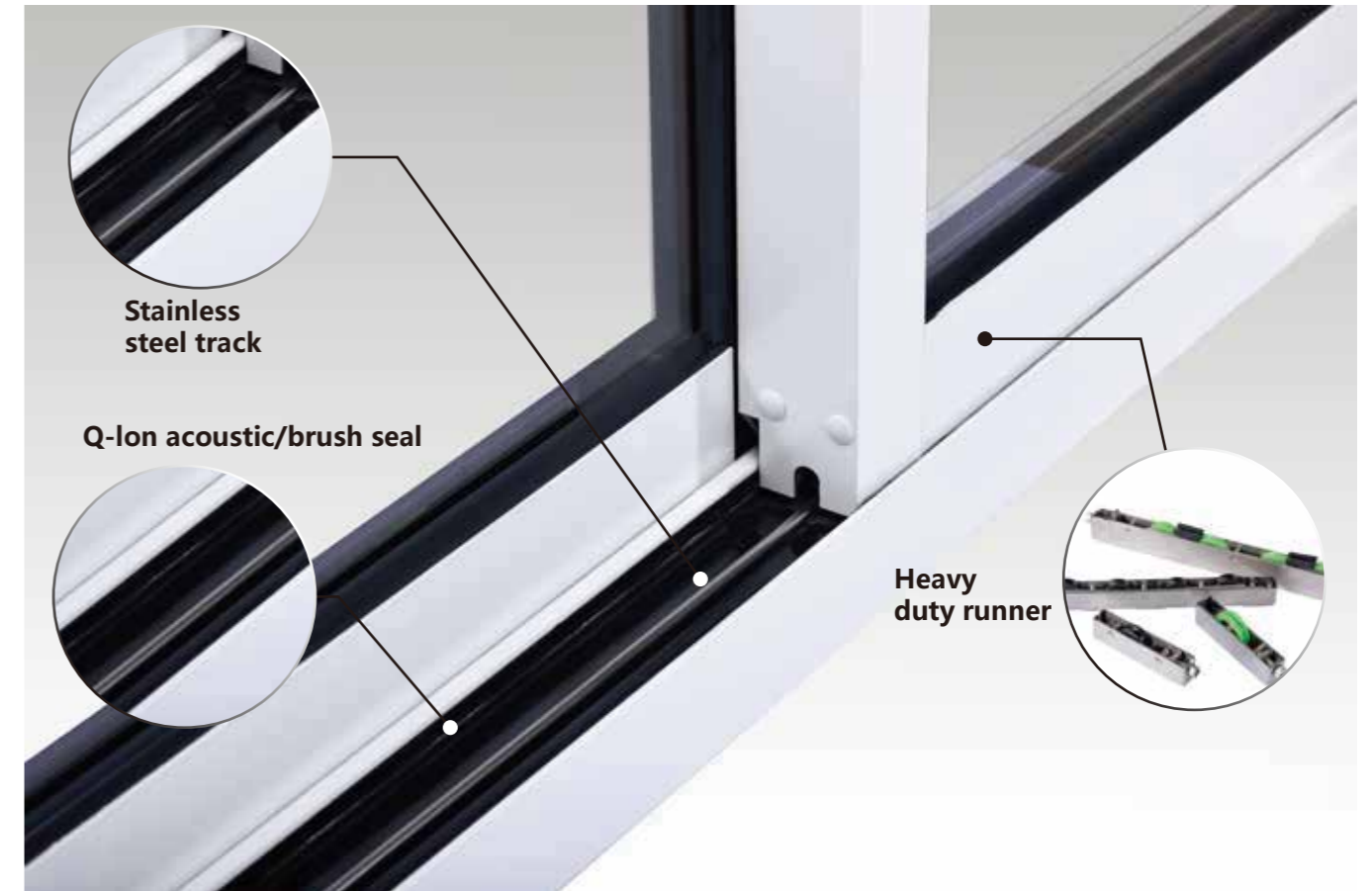

SLIDING DOOR

GL 100/150/200/250 SERIES

NON-THERMAL BREAK



Inspired by commercial grade sliding door systems, the non-thermal break Sliding Door incorporates commercial grade features within a platform purposely designed for commercial and residential applications. Intergraded with stainless steel track, nylon heavy duty runner and heavy duty mesh screen for smooth, quiet operation and your home security. The Series is a bold and unique system with up to five sliding panels in each direction. The system has been tested for compliance with the relevant Australian standards, achieving very high ultimate strength of 3300 Pa and water resistance of 300 Pa and low air infiltration. It can be paired with the Brio 612 retractable and Crimsafe heavy duty/fire rate screening system.

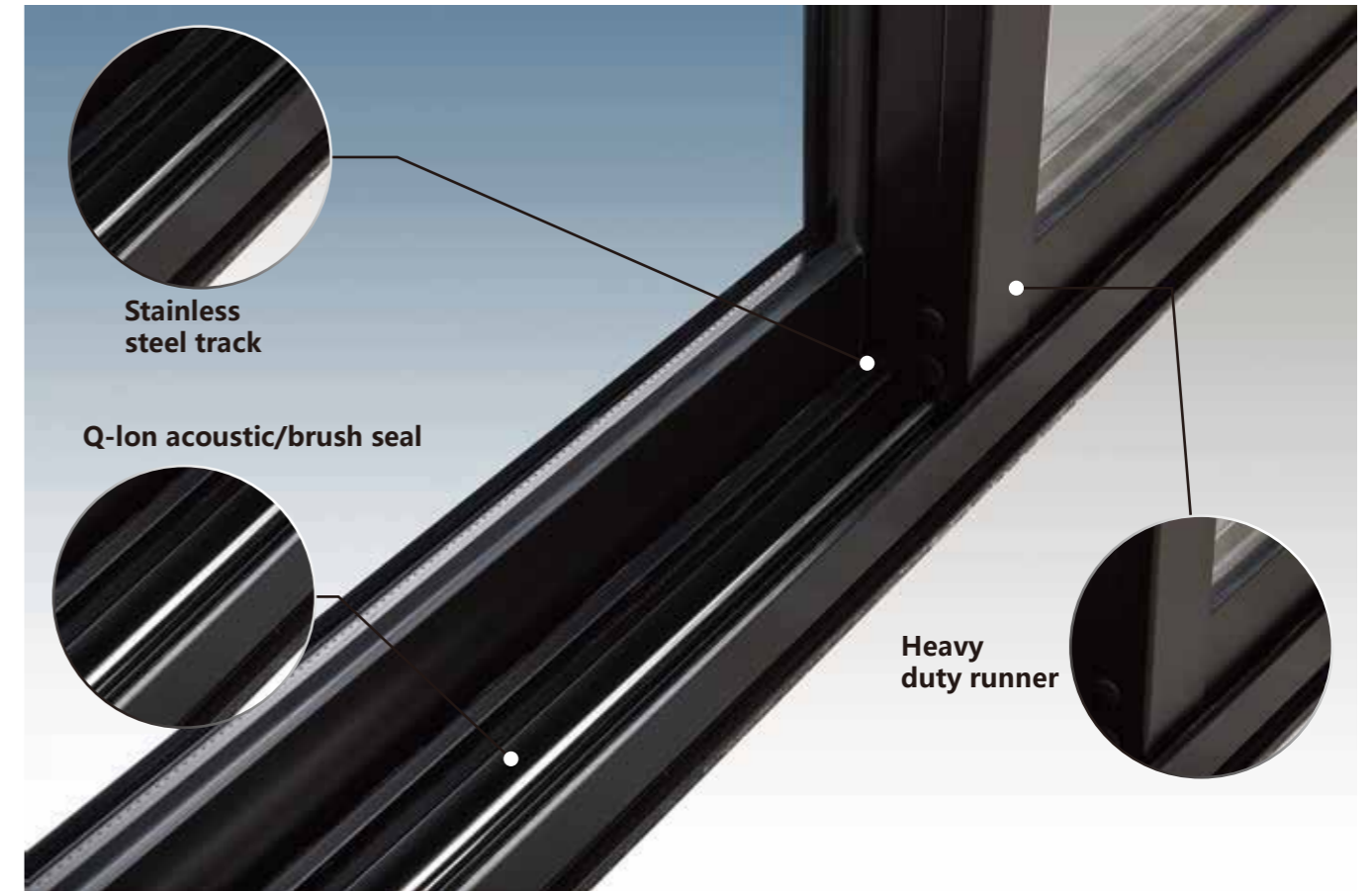

HINGED DOOR

GL 100 SERIES

NON-THERMAL BREAK



These quality commercial doors deliver excellent strength performance and are ideal for commercial and high-end residential applications. Normally, the industry standard for stiles is 44mm. But this door gives you a massive 55 mm-thick stile that outperforms the rest, every time. The strength of the door jamb has allowed when you looking to put extra thickness of toughen and safety glass for your home security, or to hang a custom solid heavy panel. The typical design has allowed the system highly integrated with Australian standard locking system of mechanical and electrical from common brand of Lockwood, Kaba, and Doric etc. Also highly integrated with Australian standard door accessories such as Raven seal, finger guard, door closer and electrical strike. It can be paired with the Crimsafe heavy duty/fire rate screening system and built-in blind into double glazing.

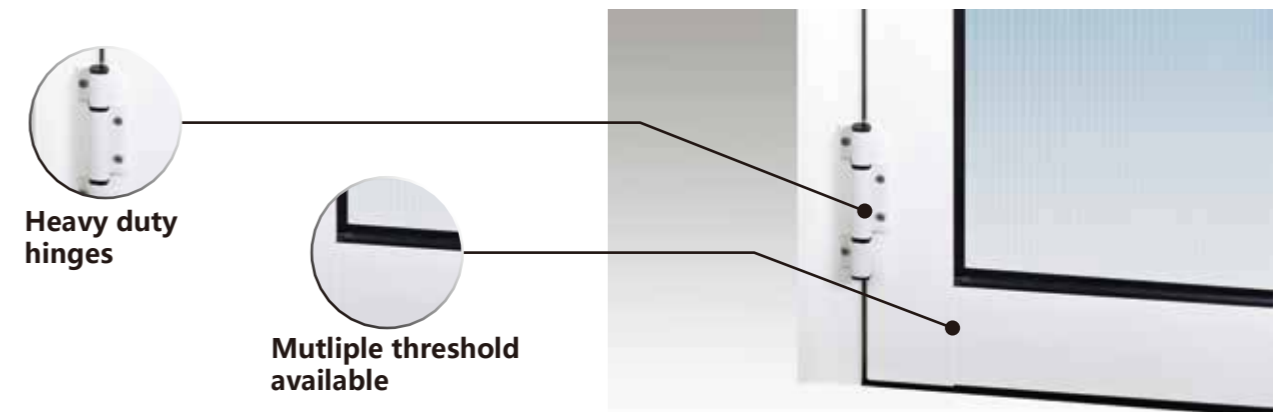

HINGED DOOR

GL 100 SERIES

THERMAL BREAK



These quality commercial doors deliver excellent strength also great thermal performance and are ideal for commercial and high-end residential applications. Normally, the industry standard for stiles is 44mm. But this door gives you a massive 55 mm-thick stile that outperforms the rest, every time. The strength of the door jamb has allowed when you looking to put extra thickness of toughen and safety glass for your home security, or to hang a custom solid heavy panel. The typical design has allowed the system highly integrated with Australian standard locking system of mechanical and electrical from common brand of Lockwood, Kaba, and Doric etc. Also highly integrated with Australian standard door accessories such as Raven seal, finger guard, door closer and electrical strike. It can be paired with the Crimsafe heavy duty/fire rate screening system and built-in blind into double glazing.

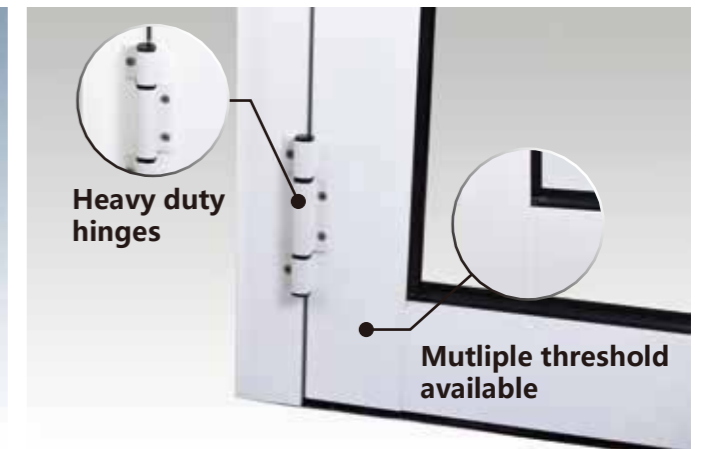

BREEZEWAY® GLASS LOURVE

GL 100 SERIES

NON-THERMAL

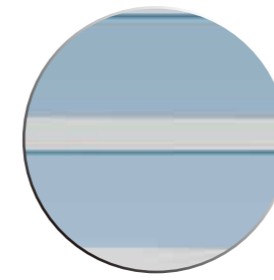

Opening restriction available



Cam handle lock



Key locked



Commercial Grade non thermal/thermal break frame



These quality commercial doors deliver excellent strength performance and are ideal for commercial and high-end residential applications. Normally, the industry standard for stiles is 44mm. But this door gives you a massive 55 mm-thick stile that outperforms the rest, every time. The strength of the door jamb has allowed when you looking to put extra thickness of toughen and safety glass for your home security, or to hang a custom solid heavy panel. The typical design has allowed the system highly integrated with Australian standard locking system of mechanical and electrical from common brand of Lockwood, Kaba, and Doric etc. Also highly integrated with Australian standard door accessories such as Raven seal, finger guard, door closer and electrical strike. It can be paired with the Crimsafe heavy duty/fire rate screening system and built-in blind into double glazing.

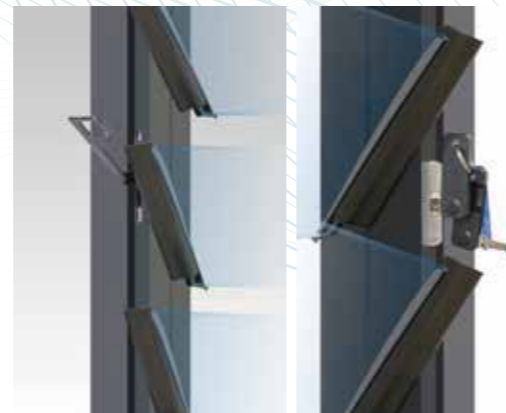

ANEETA® SASHLESS DOUBLE HUNG GL 100 SERIES THERMAL / NON-THERMAL



These quality commercial doors deliver excellent strength also great thermal performance and are ideal for commercial and high-end residential applications. Normally, the industry standard for stiles is 44mm. But this door gives you a massive 55 mm-thick stile that outperforms the rest, every time. The strength of the door jamb has allowed when you looking to put extra thickness of toughen and safety glass for your home security, or to hang a custom solid heavy panel. The typical design has allowed the system highly integrated with Australian standard locking system of mechanical and electrical from common brand of Lockwood, Kaba, and Doric etc. Also highly integrated with Australian standard door accessories such as Raven seal, finger guard, door closer and electrical strike. It can be paired with the Crimsafe heavy duty/fire rate screening system and built-in blind into double glazing.

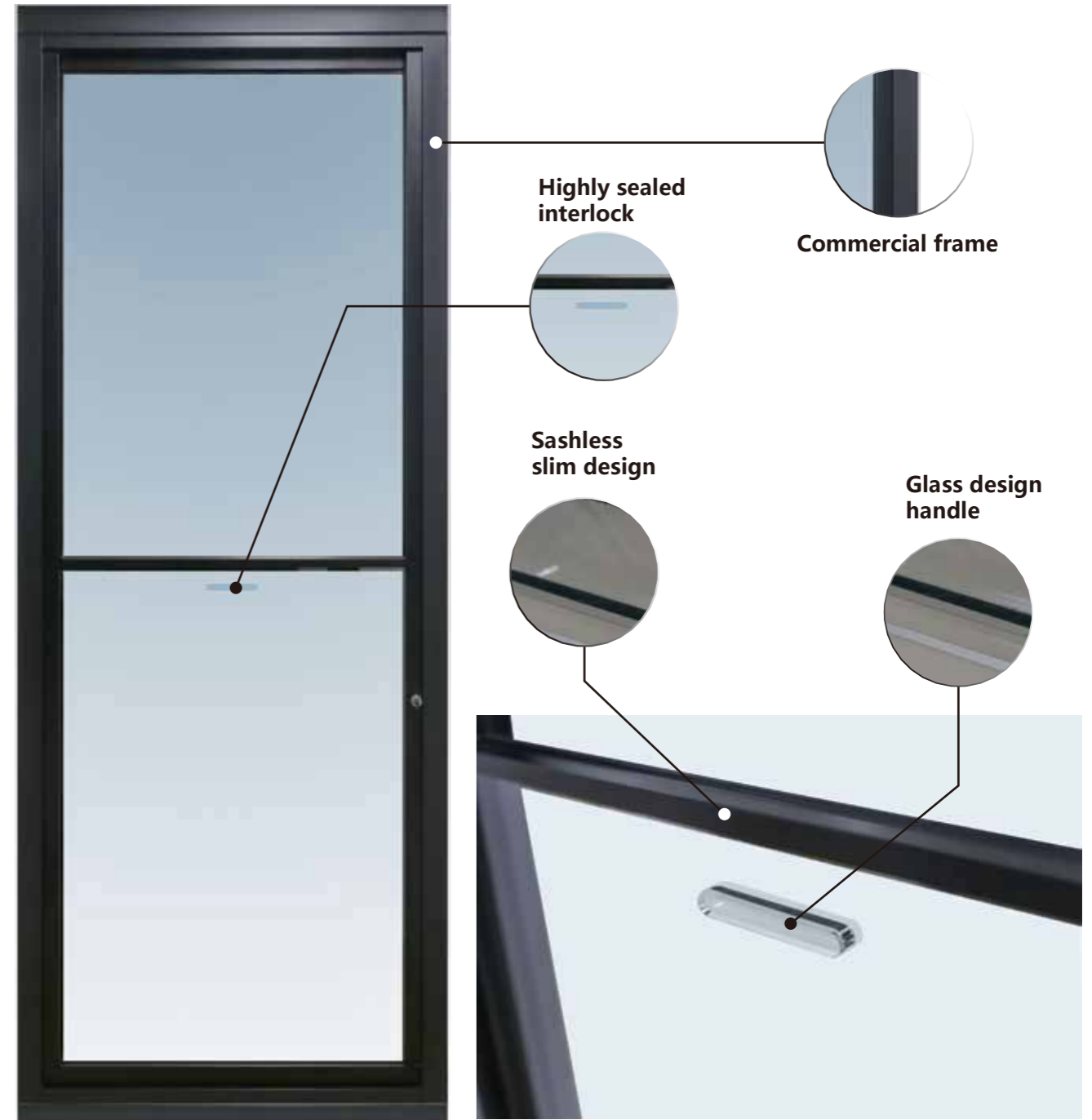

BI FOLD DOOR/WINDOW

GL 100 SERIES

NON-THERMAL



These quality commercial doors deliver excellent strength performance and are ideal for commercial and high-end residential applications. Normally, the industry standard for stiles is 44mm. But this door gives you a massive 55 mm-thick stile that outperforms the rest, every time. The strength of the door jamb has allowed when you looking to put extra thickness of toughen and safety glass for your home security, or to hang a custom solid heavy panel. The typical design has allowed the system highly integrated with Australian standard locking system of mechanical and electrical from common brand of Lockwood, Kaba, and Doric etc. Also highly integrated with Australian standard door accessories such as Raven seal, finger guard, door closer and electrical strike. It can be paired with the Crimsafe heavy duty/fire rate screening system and built-in blind into double glazing.



BI FOLD DOOR GL 80 SERIES THERMAL BREAK



These quality commercial doors deliver excellent strength performance and are ideal for commercial and high-end residential applications. Normally, the industry standard for stiles is 44mm. But this door gives you a massive 55 mm-thick stile that outperforms the rest, every time. The strength of the door jamb has allowed when you looking to put extra thickness of toughen and safety glass for your home security, or to hang a custom solid heavy panel. The typical design has allowed the system highly integrated with Australian standard locking system of mechanical and electrical from common brand of Lockwood, Kaba, and Doric etc. Also highly integrated with Australian standard door accessories such as Raven seal, finger guard, door closer and electrical strike. It can be paired with the Crimsafe heavy duty/fire rate screening system and built-in blind into double glazing.

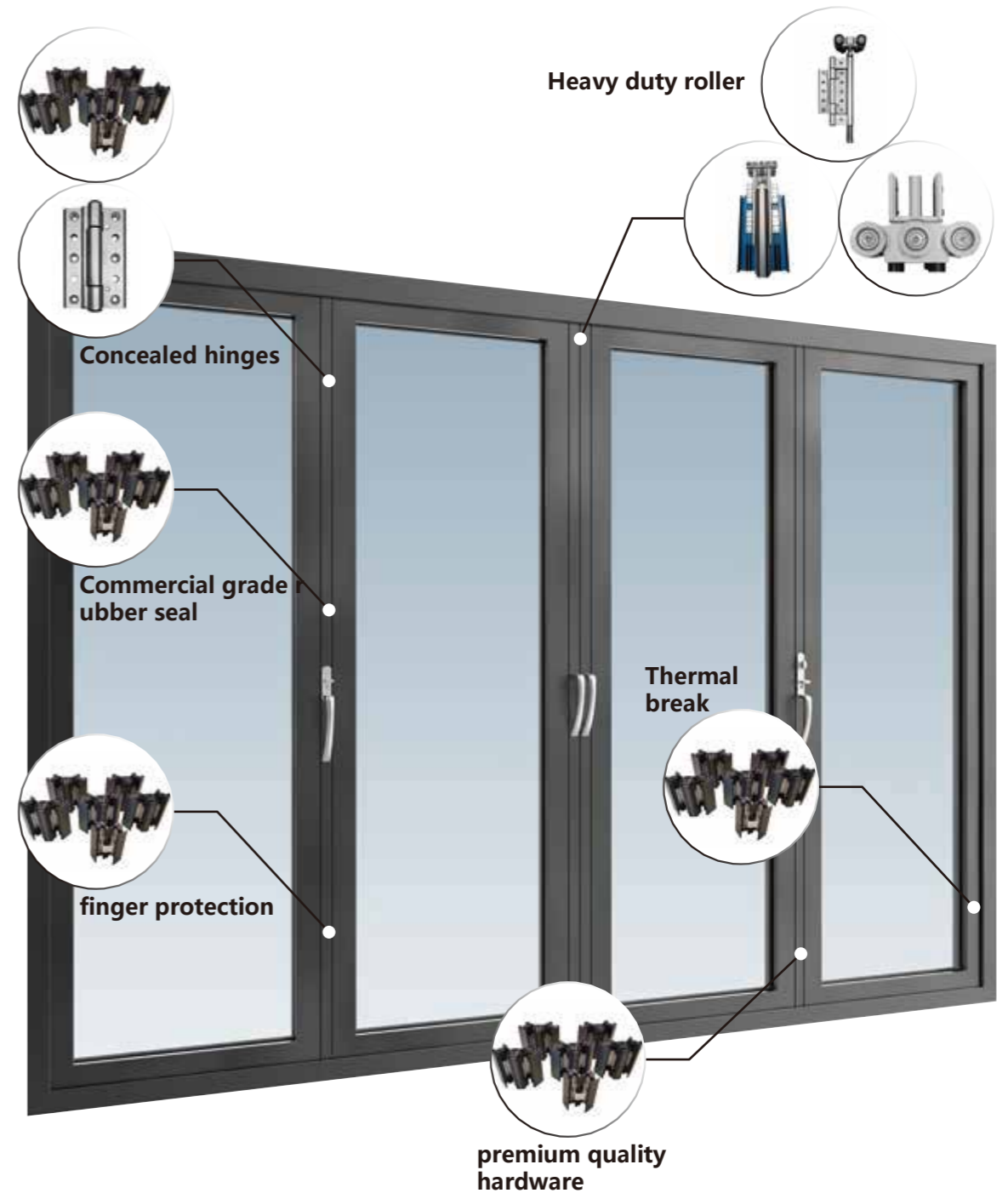

OTHER PRODUCTS AND HARDWARE

HEAVY DUTY SCREEN DOOR



BUILT IN BLINDS



OTHER HARDWARE AVAILABLE



OTHER PRODUCTS AND HARDWARE

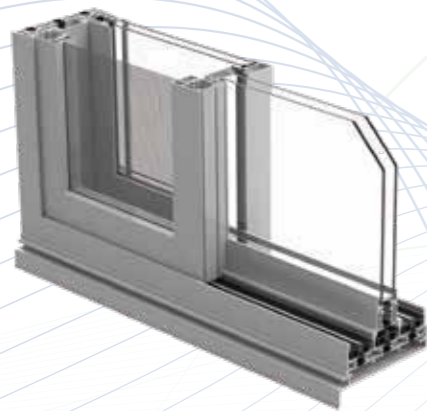
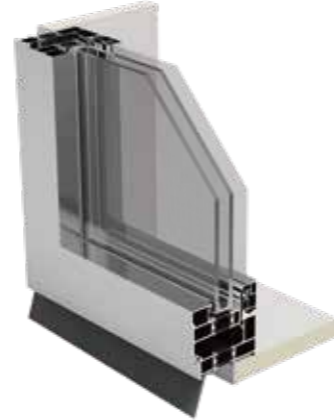
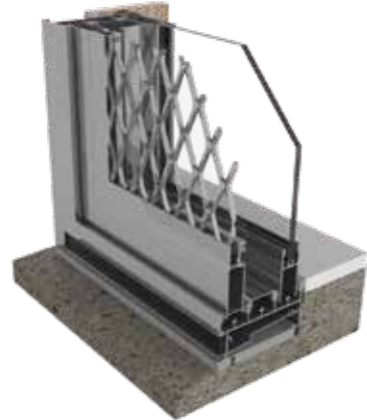
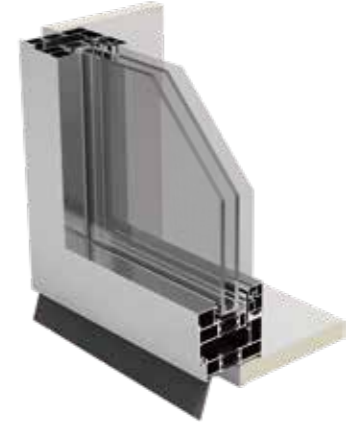

OTHER PRODUCTS AND HARDWARE

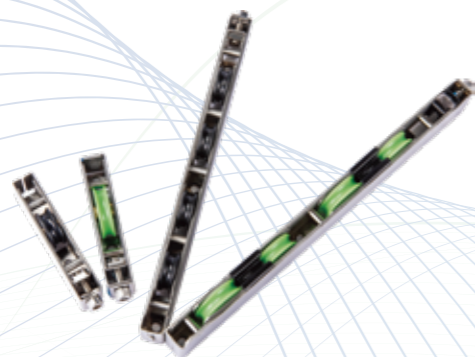
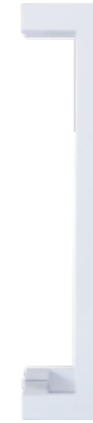

COOPERATIVE PARTNER

Green Life and the following partners,
welcome you to our Architectural Design Showroom



CONTACT US

MELBOURNE

Suite 9 / 417 Ferntree Gully Road, Mount Waverley VIC 3149

+61 3 9115 1833

sales@greenlifewindows.com.au

SYDNEY

G.02 / 36-38 Egerton Street, Silverwater NSW 2128

+61 2 9062 5771

sydney@greenlifewindows.com.au

ADELAIDE

61 South Road, Thebarton SA 5031

+61 0411 453 303

adelaide@greenlifewindows.com.au

CHINA

Factory

Houzhuang Industrial Park, Xifu Town,

Chengyang District, Qingdao City, Shandong, China

exports@greenlifewindows.com.cn

Greenlife
WINDOWS + DOORS

Why us?

- ★ Local equivalent window and door systems with local hardware.
- ★ Local powder coating brand and color in use.
- ★ Local team support and timely after sale service.
- ★ Australian standard tested systems and glass.
- ★ Direct overseas factory manufacturing price.
- ★ Proudly audited member of HIA and AWGA.

