



Suppliers of quality screens for french, bi-fold and sliding stacker doors and windows. Specialising in large openings and difficult-to-screen areas. Keep the bugs out and let the fresh air in!

Providing full enjoyment and utilisation of open plan living

Freedom Retractable Screens® Australia proudly introduce their **Infinity Zipline™ Series** to the architectural, design and construction market.

Freedom Retractable Screens® are the industry leaders of retractable insect screens, offering the perfect fusion of style and cutting-edge technology for residential and commercial applications. Led by marketplace demand, worldwide industry research has allowed Freedom Retractable Screens® to design and manufacture the most technologically advanced systems.

Years of dedicated research and development enabled us to design and manufacture this unique retractable insect screen with patented mesh-to-track retention system for Australia's harsh climatic conditions.

The Infinity Zipline™ Series is the strongest system on the market due to its outstanding wind and pressure rating. Perfect for Australian living, this unparalleled system is suited to all openings especially large windows and door spaces.

Only the highest quality components are used in our extensive product range which include our "soon to be released" solar screens.

We believe that keeping at the forefront of research, development and manufacturing, in addition to installation service, guarantees the specifier or builder are confident that they have the highest quality product available worldwide for their project.



Infinity Zipline™ double screen



HEAD OFFICE

Ph: +61 7 5593 7467
1300 727 336
Fax: +61 7 5593 7855
Mob: +61 401 022 904

Unit 3/20 Junction Road,
Burleigh Heads, QLD 4220
Email: sales@freedomscreens.com.au

DISTRIBUTORS

QUEENSLAND

Gold Coast 0428 194 545
Brisbane 1300 727 336
Toowoomba 07 4642 1773
Sunshine Coast 07 5474 4441
Wide Bay 07 5476 3270
Townsville 07 4775 4000
Cairns 07 4035 5611

TELEPHONE:

EMAIL:

russell@freedomscreens.com.au
brisbane@freedomscreens.com.au
toowoomba@freedomscreens.com.au
freedomscreens@optusnet.com.au
freedomscreens2@bigpond.com.au
townsville@freedomscreens.com.au
freedom.screens@bigpond.com.au

NEW SOUTH WALES

Sydney 1300 727 336
Newcastle 1300 727 336
Coffs Harbour 02 6658 0400
Northern Rivers 1300 727 336
South Coast 0407 236 630

CANBERRA

Canberra & South West NSW 02 6260 1824
canberra@freedomscreens.com.au

VICTORIA

Victoria 03 9428 7696
info@freedomscreensvictoria.com.au

TASMANIA

Tasmania 03 62 788 887
peter@taylorscreens.com.au

SOUTH AUSTRALIA

South Australia 1300 727 336
info@freedomgroup.net.au

WESTERN AUSTRALIA

Western Australia 08 9244 7436
freewa@bigpond.net.au

NORTHERN TERRITORY

Northern Territory 0439 003 600
screens@4frontenergy.com.au



Innovative insect screen solutions for modern Australian living

www.freedomscreens.com.au

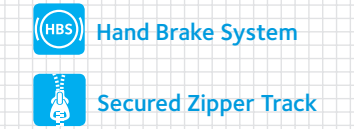
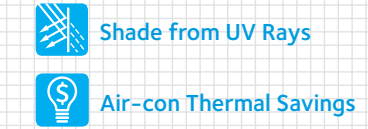
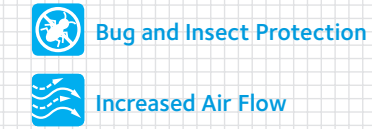
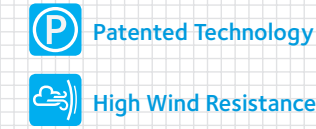

CALL 1300 727 336 to speak to one of our dedicated technical support staff

Infinity Zipline™ Series features:

- Spans up to 4.5 metres in a single screen and 9 metres in a double screen.
- Unique mesh-to-track retention system which prevents sagging and stops mesh blowouts. High wind resistance.
- Accredited NATA Laboratory results of up to 590kg pressure rating and a cyclone rating of up to 350km/h.
- Made with quality Australian aluminium.
- Recessed track option assists in the integration of door with screen installation.
- Available in a variety of finishes including powder-coated and anodised aluminium, coloured end-caps and brake levers.
- Nationwide distribution network with parts and service back-up.
- Exclusive Patented Brake System.
- Can be retrofitted to all makes of doors.
- Easily serviced.
- 5 year limited warranty.
- Several international patents.
- 100% Australian designed and manufactured.
- Durable construction.
- Freedom Retractable Screens established in 1999.
- Motorised options available.

Recessed track channel

Tracks can be recessed to suit flush fit doors, fully integrated with door system.

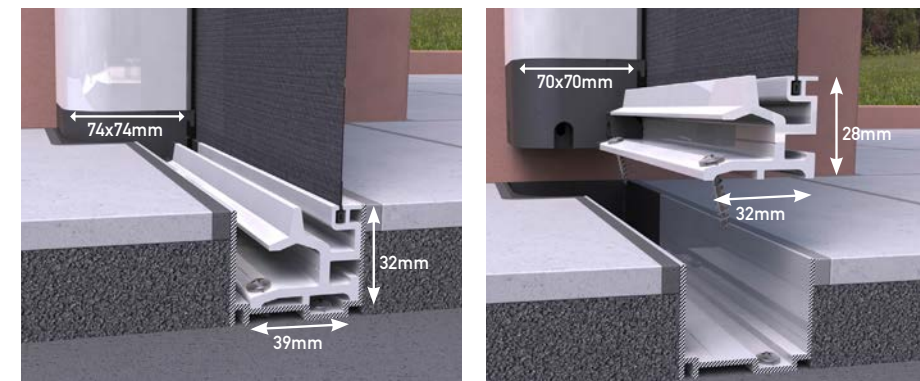

Infinity Zipline™ screen components

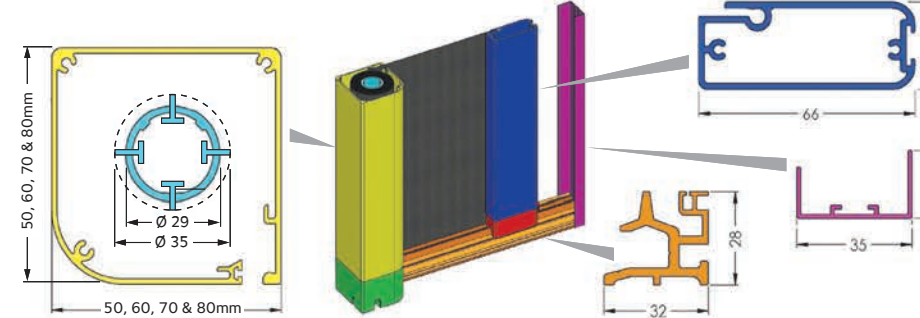

Infinity Zipline™ screen limits

The Infinity Zipline™ screens can span 4.5 metres in a single unit and up to 9.0 metres in a double unit. The Infinity Zipline™ Series is also available in a pull-down style or with a remote control (motorised) for windows, doors and enclosures. All Infinity Zipline™ screens are custom-made to exact requirements, and are available in a range of popular colours and finishes. All screens are supplied and fitted by our professional installers.

Housing	Single screen	Double screen
50mm Patio Mesh Pet Mesh	1200mm maximum 3000mm H x up to 1200mm W 3000mm H x up to 1100mm W	2400mm maximum 3000mm H x up to 2400mm W 3000mm H x up to 2200mm W
60mm Patio Mesh Pet Mesh	2200mm maximum 3000mm H x up to 2200mm W 3000mm H x up to 1800mm W	4400mm maximum 3000mm H x up to 4400mm W 3000mm H x up to 3600mm W
70mm Patio Mesh Patio Mesh Pet Mesh	3400mm maximum 3000mm H x up to 2600mm W 2700mm H x up to 3400mm W 3000mm H x up to 3000mm W	6800mm maximum 3000mm H x up to 5200mm W 2700mm H x up to 6800mm W 3000mm H x up to 6000mm W
80mm Patio Mesh Patio Mesh Pet Mesh	4500mm maximum 3000mm H x up to 2600mm W 2700mm H x up to 4500mm W 3000mm H x up to 4000mm W	9000mm maximum 3000mm H x up to 5200mm W 2700mm H x up to 9000mm W 3000mm H x up to 8000mm W

Colour selection – Special anodised colours available, please select from the Dulux and Interpon range, Visit the Download Centre on our website, www.freedomscreens.com.au.

Infinity Zipline™ screen corner solution

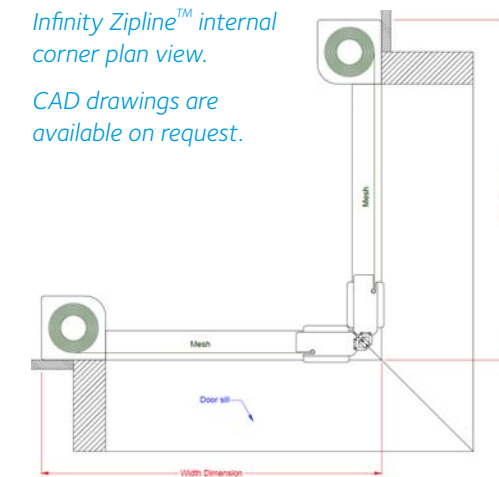

Freedom Screens unique patented Brake System

The Infinity Zipline™ Series is easy to operate with the patented brake system that allows the screen to stop in any position along the track without the screen springing back.

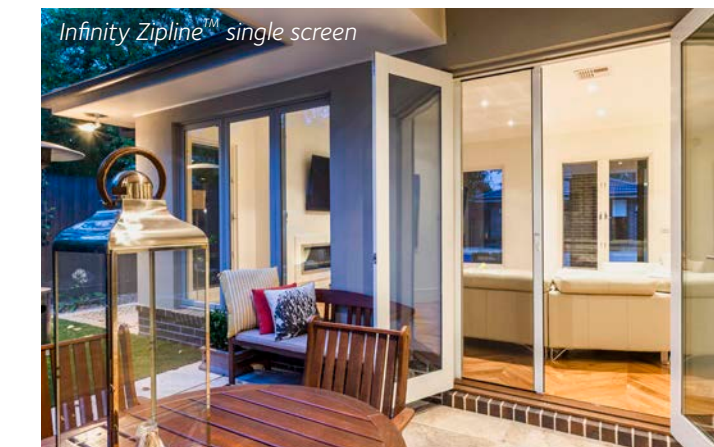
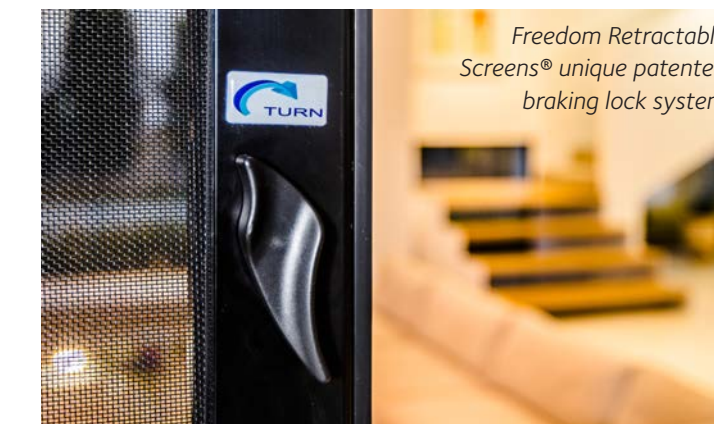

Freedom Retractable Screens® NATA tested wind rating

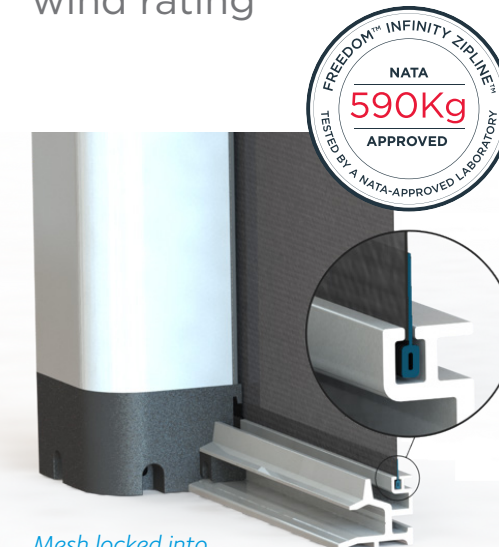

Mesh locked into track to resist high wind mesh blowouts.

“The testing is complete; we could not break the Infinity Zipline™ Screen.”

Jeffrey Profke, CEO of ANTL, a NATA accredited laboratory.

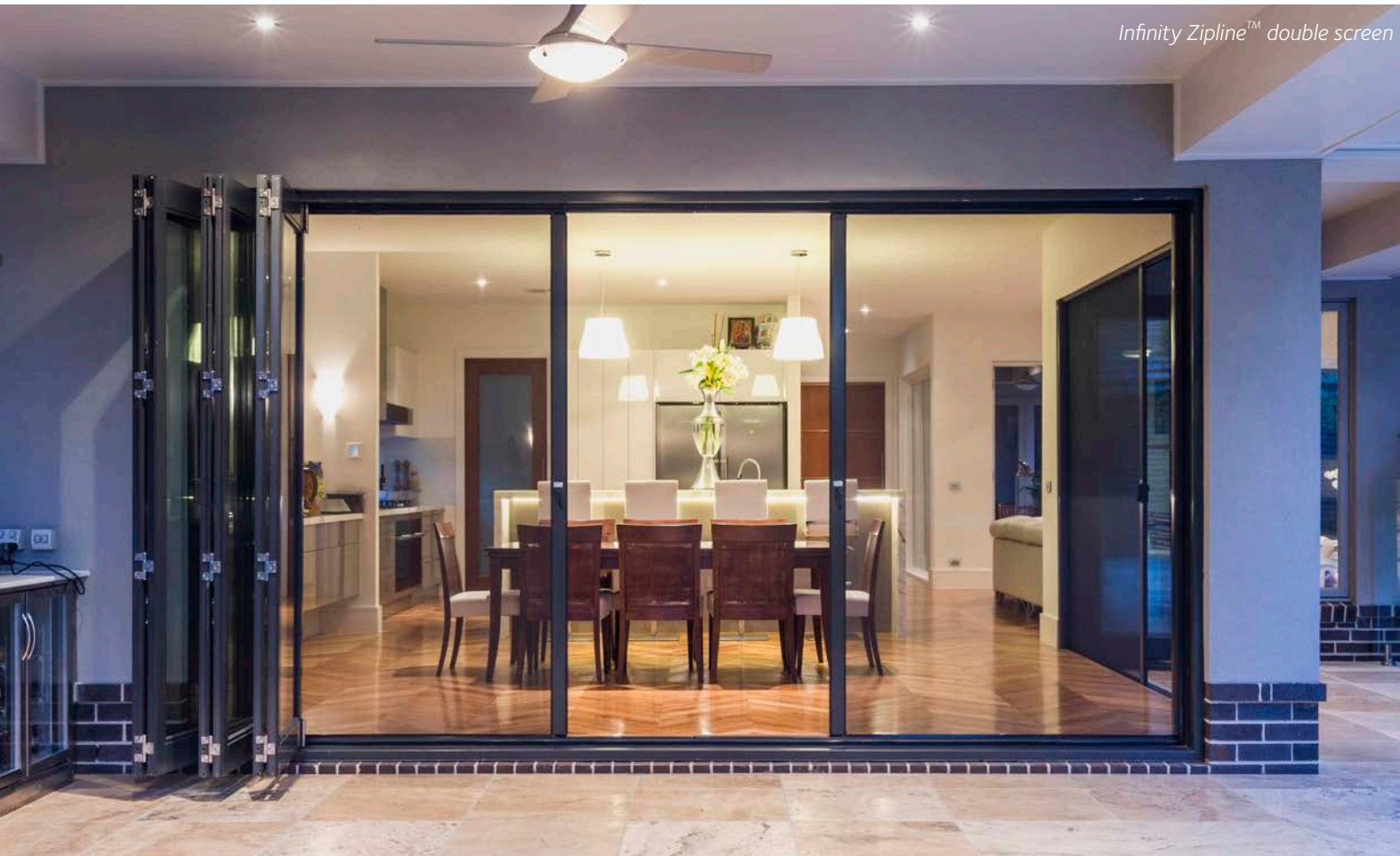

Infinity Zipline™ double screen